

JOURNAL OF
SCIENTIFIC
PERSPECTIVES

J S P

International Peer-Reviewed and Open Access Electronic Journal



ratingacademy.com.tr/ojs

Volume / Cilt : 4

Issue / Sayı : 2

Year / Yıl : 2020

E-ISSN : 2587-3008

DOI : 10.26900

JOURNAL OF
SCIENTIFIC
PERSPECTIVES

J S P

ABOUT THE JOURNAL

Journal of Scientific Perspectives (JSP) is a **scholarly** and **international peer-reviewed journal**. It is published quarterly in *January, April, July* and *October*, in the fields of **basic sciences, engineering, natural sciences** and **health sciences**. All articles submitted for publication are evaluated by the editor-in-chief, field editor, editorial board and referees. The original research papers, technical notes, letter to the editor, debates, case presentations and reviews, only in *English*, are published in the journal. Thus, it aims to bring together the views and studies of academicians, researchers and professionals working in the fields mentioned above.

Journal of Scientific Perspectives is an *open access electronic journal*. All articles published in the journal, are assigned the *DOI number*. Article submission and follow-up process are carried out by the manuscript submission system.

OWNER

RATING ACADEMY

Ar-Ge Yazılım Yayıncılık Eğitim Danışmanlık ve Organizasyon Ticaret Limited Şirketi

EDITORS

Assoc. Prof. Dr. Özlem YAYINTAŞ

Çanakkale Onsekiz Mart University, Çanakkale/TURKEY
(Chief Editor)

Prof. Dr. Emin Uğur ULUGERGERLİ

Canakkale Onsekiz Mart University, Canakkale, Turkey
(Co-Editor)

SECTION EDITORS

Basic Sciences and Engineering

Prof. Dr. Ayhan EŞİ

Adiyaman University, Adiyaman/TURKEY

Health Science

Prof. Dr. Gülbu TANRIVERDİ

Çanakkale Onsekiz Mart University, Çanakkale/TURKEY

Natural Sciences

Prof. Dr. Levent ŞIK

Celal Bayar University, Manisa/TURKEY

MANAGING EDITOR & WEB EDITOR

Cumali YAŞAR

Çanakkale Onsekiz Mart University, Turkey

Contact

Sarıcaeli Köyü ÇOMÜ Sarıcaeli Yerleşkesi No: 119, Çanakkale / TÜRKİYE

E-mail: jsp@ratingacademy.com.tr

Web: <https://ratingacademy.com.tr/journals/index.php/jsp>

EDITORIAL BOARD

Prof.Dr. Trajče STAFILOV, Institute of Chemistry Faculty of Science Ss. Cyril and Methodius University, PO Box 162, 1001 Skopje, Republic of Macedonia, Macedonia, the former Yugoslav Republic of

Prof.Dr. Alireza HEIDARI, Director of the BioSpectroscopy Core Research Laboratory at Faculty of Chemistry, California South University (CSU), Irvine, California, USA & President of American International Standards Institute (AISI) Irvine, California, USA, United States

Prof.Dr. S. A. MOHIUDDINE, Department of Mathematics, King Abdulaziz University, Jeddah, Saudi Arabia

Prof. Dr. Khaldia Inayat NOOR, Comsats Institute Information Technology, Pakistan

Prof. Dr. Muhammad Aslam NOOR, Comsats Institute Information Technology, Pakistan

Prof. Dr. Adem KILICMAN, University Putra Malaysia, Dept.of Mathematics, Malaysia

Prof.Dr. Vakeel A. KHAN, Aligarh Muslim University, Dept.of Mathematics, India

Prof. Dr. Necati MENEK, Ondokuz Mayıs University, Faculty of Science and Arts, Department of Chemistry, Samsun, Turkey

Prof.Dr. Vesna P. Stankov JOVANOVIĆ, Nis University, Faculty of Sciences and Mathematics, Department of Chemistry, Nis, Serbia

Prof. Dr. William R. BUCK, Institute of Systematic Botany New York Botanical Garden Bronx, NY, United States

Prof. Dr. Galin Yordanov IVANOV, University of Food Technologies, Department of Food Preservation and Refrigeration, Plovdiv, Bulgaria

Prof. Dr. Bipan HAZARIKA, Rajiv Gandhi University, Department of Mathematics, India

Prof. Dr. Binod Chandra TRIPATHY, Tripura University, Department of Mathematics, India

Prof. Dr. Sławomira SKRZYPEK, University of Lodz (Poland), Faculty of Chemistry, Łódź, Poland

Prof. Dr. Agnieszka NOSAL-WIERCIŃSKA, University of Maria Curie-Skłodowska, Faculty of Chemistry, Department of Analytical Chemistry and Instrumental Analysis, Maria Curie-Skłodowska, Poland

Prof. Dr. Umur ÖNAL, Çanakkale Onsekiz Mart University, Faculty of Marine Sciences and Technology, Department of Aquaculture, Çanakkale, Turkey

Prof. Dr. Selehattin YILMAZ, Canakkale, Turkey, Canakkale Onsekiz Mart University, Faculty of Sciences and Arts, Department of Chemistry, Turkey

Prof. Dr. Özlem SÖĞÜT, Ege University, Faculty of Pharmacy, Department of Analytical Chemistry, Turkey

Prof. Dr. Neşet AYDIN, Çanakkale Onsekiz Mart University Faculty of Sciences and Arts, Department of Mathematics, Turkey

Prof. Dr. Gülnur EMİNGİL, Ege University, School of Dentistry, Department of Peridontology, Turkey

Assoc. Prof. Dr. Halil Fatih AŞGÜN, Çanakkale Onsekiz Mart University, Medicine Faculty, Surgery Department, Turkey

Assoc. Prof. Dr. Bahadır KIRILMAZ, Çanakkale Onsekiz Mart University, Medicine Faculty, Cardiology Department, Turkey

Assoc. Prof. Dr. Pınar ERKEKOĞLU, Hacettepe University, Faculty of Pharmacy, Turkey

Assist. Prof. Dr. Nuri SOLAK, Istanbul Technical University, Faculty of Chemical and Metallurgical Engineering, Department of Metallurgical and Materials Engineering, Turkey

Assist. Prof. Dr. Sibel MENTEŞE, Çanakkale Onsekiz Mart University, Faculty of Engineering, Department of Environmental Engineering, Turkey

Assist. Prof. Dr. Deniz ŞANLIYÜKSEL YÜCEL, Çanakkale Onsekiz Mart University, Faculty of Engineering, Department of Mining Engineering, Turkey

Assist. Prof. Dr. Bharat POKHAREL, Collage of Agriculture, Human and Natural Science, Department of Agricultural and Environmental Science, Tennessee State University, United States

Dr. Med. Serdar ÖZGÜÇ, İzmir Tabip Odası, Phytotherapy and Homeopathy, İzmir, Turkey

Dr. Prof. Dr. Malgorzata WISNIEWSKA, University of Maria Curie-Sklodowska, Faculty of Chemistry, Department of Radiochemistry and Colloid Chemistry, Lublin, Poland

THE REFEREES IN THIS ISSUE

Prof. Dr. Abel CARRASQUILLA, *Northern Rio de Janeiro State University Darcy Ribeiro, BRAZİL*

Prof. Dr. Meliha GEMİCİ, *Ege University, TURKEY*

Prof. Dr. Mustafa YAŞAR, *Karabük University, TURKEY*

Prof. Dr. Neşet AYDIN, *Çanakkale Onsekiz Mart University, TURKEY*

Prof. Dr. Okan ACAR, *Çanakkale Onsekiz Mart University, TURKEY*

Prof. Dr. Sergii NESTERENKO, *National Polytechnic University, UKRAINE*

Prof. Dr. Tolga OZTURK, *İstanbul University, TURKEY*

Prof. Dr. Valerii PLOTNIKOV, *Odessa National Academy of Food Technologies, UKRAINE*

Assist. Prof. Dr. Aykut OR, *Çanakkale Onsekiz Mart University, TURKEY*

Assist. Prof. Dr. Göktuğ GÜNKAYA, *Anadolu University, TURKEY*

Assist. Prof. Dr. Muhittin İNAN, *İstanbul University, TURKEY*

Assist. Prof. Dr. Neslihan DEMİR, *Çanakkale Onsekiz Mart University, TURKEY*

Assist. Prof. Dr. Sefer DEMİRBAŞ, *Tekirdağ Namık Kemal University, TURKEY*

Assist. Prof. Dr. Tuna AYDIN, *Kırıkkale University, TURKEY*

THE AIM AND SCOPE OF THE JOURNAL

Journal of Scientific Perspectives provides open access to its content, embracing the principle of increasing the global sharing of information on free scientific research. This journal is a material in which academic studies are included and so, it provides a social service for the benefit of institutions and individuals engaged in scientific research as. In this context, it is aimed at providing readers with a common platform to share and improve the quality of recent research advancements in the fields of **basic sciences, engineering, natural and health sciences**. Thus, It is aimed at promoting research worldwide and publishes basic and advanced research work from the fields above.

The journal accepts only original works of quality which are products of a new solution approach or give a new view of an existing knowledge. In this context, it is open to any kind of constructive, creative and institutionalized knowledge providing that they contribute to universal science and technology. Thus, it is aimed to index the journal with various international indexes.

The study fields covered by the journal are

Basic Sciences and Engineering

- ❖ Chemical Engineering
- ❖ Computer Engineering and Informatics
- ❖ Constructional Engineering
- ❖ Environmental Engineering
- ❖ Electrical and Electronic Engineering
- ❖ Food Engineering
- ❖ Geology Engineering
- ❖ Industrial Engineering
- ❖ Mechanical Engineering
- ❖ Mining Engineering
- ❖ Physical Engineering
- ❖ Textile Engineering
- ❖ Other Engineering Fields
- ❖ Chemistry
- ❖ Physics
- ❖ Mathematics
- ❖ Statistics
- ❖ Materials Sciences
(Material and Metallurgy Engineering, Topographical Engineering etc.)
- ❖ Space Sciences
- ❖ Earth Sciences
- ❖ Architecture
- ❖ Urban and Regional Planning
- ❖ Astronomy and Astrophysics

Health Sciences

- ❖ Medical Sciences (Surgery, International Medicine, Basic Medical Sciences)
- ❖ Dentistry
- ❖ Pharmacology and Pharmaceutics
- ❖ Nursing
- ❖ Nutrition and Dietary
- ❖ Veterinary Medicine

Natural Sciences

- ❖ Biology
- ❖ Environmental Sciences
- ❖ Food Science and Technology
- ❖ Animal Husbandary
- ❖ Forestry
- ❖ Marine, Aquatic Sciences and Fisheries
- ❖ Agricultural Science

There are no limits to the fields in which the study will be accepted to the journal. The journal is open to all works aimed at contributing to the national and international developments of the professional organizations and individuals who follow the developments in the field of health, science and engineering and to create a resource in these fields.

PUBLICATION POLICIES

1. *Journal of Scientific Perspectives* has begun publication in July 2017. It is an internationally peer-reviewed and periodical journal published regularly in four issues per year in **January, April, July and October**, in the fields of **basic sciences, engineering, natural sciences and health sciences**. All articles submitted for publication are evaluated by the editor in chief, field editor, editorial board and referees.
2. Journal only accepts the studies written in **English**. Original research papers, technical notes, letters to the editor, discussions, case reports and compilations are published in our journal.
3. Only the original scientific researches are included. It is essential that the information created in scientific study needs to be new, suggest new method or give a new dimension to an existing information
4. Journal of Scientific Perspectives is an **open access electronic journal**. All articles published in the journal are assigned the **DOI number**. Researchers worldwide will have full access to all the articles published online and can download them with zero subscription fees. In addition, because of the influence of your research, you will quickly become an Open Access (OA) author, because an OA article has more chances to be used and the plods through the subscription barriers of traditional publishing models.
5. The editor-in-chief and the relevant field editor have the authority not to publish the articles, to make regulations based on the format or to give back to the author for correction that do not comply with the conditions of publication within the knowledge of the editorial board. All studies submitted to *Journal of Scientific Perspectives* are sent to at least **two referees** after the initial review of the editor in chief, relevant field editor and editors related to the study issue with respect to formatting and content. After having positive feedbacks from both of the referees, the manuscripts are published. In case of having one positive and one negative feedback from the referees, the manuscript is sent to **a third referee**. Identities of authors are kept in the posts to be sent to the referees (Double-blind peer review). In addition, the authors are not informed about the referee
6. It is general essential that studies which aren't seemed enough need to be changed in accordance with suggests of referees. Studies which aren't reached intended level or aren't seemed enough in terms of scientific are refused with unexplained reason. The works are published with the condition to be taken in order
7. The referee process is carried out by the **editor in chief**. A study that the chief editor does not find suitable or does not accept is not included in the journal. In this regard, authors can not create a liability for the journal and other boards of the journal.

8. After the field editor has been appointed by the editor in chief, **7 days** are given to him/her for the appointment of the referee. While he/she appoints the referees, he takes the views of the other editors related to the study issue. The studies sent to the referees for evaluation are expected to be answered within **30 days**. In case this is overcome, the editor makes a new referee appointment and withdraws the request from the former referee.
9. Required changes must be made by the author within **15 days** after the decision of "Correction required" given in article acceptance decision.
10. The studies submitted for publication in the journal must have not been published elsewhere or have not been sent another journal to be published. The studies or their summaries which were presented in a conference or published can be accepted if it is indicated in the study. In addition, if the work is supported by an institution or is produced from a dissertation, this should be indicated by a footnote to the title of the work. Those who want to withdraw their publications for publication for some reason must apply to the journal management with a letter. The editorial board assumes that the article owners agree to abide by these terms.
11. All responsibility of the studies belong to the authors. Studies should be prepared in accordance with international scientific ethics rules. Where necessary, a copy of the ethics committee report must be added.
12. The articles submitted to the *Journal of Scientific Perspectives* are sent to the referees after they have been checked with the "iThenticate" plagiarism scanning program to see if they are partially or completely copied (plagiarism) from another study. Regulation is demanded from the author for the articles which are high in the plagiarism result (30% and over). If the required regulation is not made within **60 days**, the study is rejected.
13. Copyright of all published studies belongs to the *Journal of Scientific Perspectives*.
14. **No copyright payment** is made.
15. For the studies accepted for publication in our journal, copyright transfer form signed must be added to the system or mail to
16. No study has differentiation or superiority from another study. Each author and study has the same rights and equality. No privileges are recognized.
17. Studies submitted for publication in our journal must be prepared according to the rules of spelling of journal. Spelling and template are included in are included in the "Author Guidelines" heading
18. Articles submitted for evaluation must not exceed 25 pages after they are prepared according to the specified template. Article summary should not exceed 300 words and minimum 3 and maximum 7 keywords should be written.

ETHICAL GUIDELINES

Journal of Scientific Perspectives (JSP) is committed to meeting and upholding standards of ethical behaviour at all stages of the publication process. It strictly follows the general ethical guidelines provided by the Committee on Publication Ethics (COPE) and the Open Access Scholarly Publishers Association (OASPA). Depending on these principles and general publication requirements, editors, peer reviewers, and authors must take the following responsibilities in accordance to professional ethic and norms. The proper and ethical process of publishing is dependent on fulfilling these responsibilities.

1. The Responsibilities of Editors

1.1. The General Responsibilities

- Editors should be accountable for everything published in their journals.
- The editor should make the efforts to improve the quality of and contribute to the development of the journal.
- The editor should support authors' freedom of expression.

1.2. Relations with Readers

- Readers should be informed about who has funded research or other scholarly work and whether the funders had any role in the research and its publication and, if so, what this was.
- The editor should ensure that the non-peer-reviewed sections of the journal (letters, essays, announcements of conferences etc.) are clearly identified.
- The editor should make efforts to ensure that the articles published align with the knowledge and skills of the readers.

1.3. Relations with Reviewers

- The editor should match the knowledge and expertise of the reviewers with the manuscripts submitted to them to be reviewed ensuring that the manuscripts are adequately reviewed by qualified reviewers.
- The editor should require reviewers to disclose any potential competing interests before agreeing to review a submission.
- The editor should provide necessary information about the review process to the reviewers about what is expected of them.
- The editor must ensure that the review process is double blind and never reveal the identities of the authors to the reviewers or vice versa.
- The editor encourage reviewers to evaluate manuscripts in an objective, scientific and objective language.

- The editor should develop a database of suitable reviewers and update it on the basis of reviewer performance and timing
- In the reviewer database; It should be attentive to scientists who evaluate the manuscripts objectively, perform the review process on time, evaluate the manuscript with constructive criticism and act in accordance with ethical rules.

1.4. Relations with Authors

- The editor should provide clear publication guidelines and an author guidelines of what is expected of them to the authors and continuously review the guidelines and templates.
- The editor should review the manuscript submitted in terms of guidelines of the journal, importance of the study, and originality and if the decision to reject the manuscript is made editor should explain it to the authors with clear and unbiased way. If the decision is made that the manuscript should be revised by the authors in terms of written language, punctuation, and/or rules in the guidelines (spacing, proper referencing, etc.) the authors should be notified and given time to do the corrections accordingly.
- The authors should be provided with necessary information about the process of their review (at which stage is the manuscript at etc.) complying with the rules of double blind review.
- In the case of an editor change, the new editor should not change a decision taken by the previous editor unless it is an important situation.

1.5. Relations with Editorial Board Members

- Editor should provide publication policies and guidelines to the editorial board members and explain what is expected of them.
- Editor should ensure that the editorial board members have the recently updated publication guidelines and policies.
- Editor should review the editorial board members and include members who can actively contribute to the journal's development.
- Editorial board members should be informed about their roles and responsibilities such as
 - Supporting development of the journal
 - Accepting to write reviews in their expertise when asked
 - Reviewing publication guidelines and improving them consistently
 - Taking responsibility in journal's operation

2. The Ethical Responsibilities of Reviewers

- The reviewers must only agree to review manuscripts which align with their expertise.
- The reviewers must make the evaluation in neutrality and confidentiality. In accordance with this principle, they should destroy the manuscripts they examine after the evaluation process, but use them only after they are published. Nationality, gender, religious belief, political belief and commercial concerns should not disrupt the neutrality of the assessment.

- The reviewers must only review manuscripts which they do not have any conflict of interests. If they notice any conflict of interest they should inform the editor about it and decline to be a reviewer to the related manuscript.
- Reviewers must include the Manuscript Evaluation Form for the manuscripts they evaluate without indicating their names to protect the blind review process. And they should include their final decision about the manuscript whether or not it should be published and why.
- The suggestions and tone of the reviews should be polite, courteous and scientific. The reviewers should avoid including hostile, disrespectful, and subjective personal comments. When these comments are detected they could be reviewed and returned to the reviewer to be revised by the editor or editorial board.
- The reviewers should respond in time when a manuscript is submitted to them to be reviewed and they should adhere to the ethical responsibilities declared hereby.

3.The Ethical Responsibilities of Author(s)

- Submitted manuscripts should be original works in accordance with the specified fields of study.
- Manuscripts sent for publication should not contradict scientific publication ethics (plagiarism, counterfeiting, distortion, republishing, slicing, unfair authorship, not to mention the supporting organization).
- The potential conflicts of interest of the author(s) should be stated and the reason should be explained
- The bibliography list is complete and should be prepared correctly and the cited sources must be specified.
- The names of the people who did not contribute to the manuscript should not be indicated as an authors, they should not be suggested to change the authors order, remove the author, or add an author for a manuscript that is submitted for publication. Nevertheless, they should identify individuals who have a significant share in their work as co-authors. A study cannot be published without the consent of all its authors.
- Author(s) are obliged to transmit the raw data of the manuscript to the editor upon request of journal editors.
- The author(s) should contact the editor to provide information, correction or withdrawal when they notice the error regarding the manuscript in the evaluation and early view phase or published electronically.
- Author (s) must not send manuscripts submitted for publication to another journal at the same time. Articles published in another journal cannot be resubmitted to be published in the Journal of Scientific Perspectives (JSP).
- In a manuscript that has reached the publication stage, the authors should fill in the "Copyright Transfer Form" and forward it to the editor.

4.The Ethical Responsibilities of Publisher

- The publisher acknowledges that the decision making process and the review process are the responsibility of the editor of Journal of Scientific Perspectives (JSP)
- The publisher is responsible for protecting the property and copyright of each published article and keeping a record of every published copy.
- The publisher is obliged to provide free access to all articles of the journal in electronic environment.

Plagiarism and unethical behavior

All manuscripts submitted to Journal of Scientific Perspectives (JSP) are reviewed through [iThenticate](#) software before publishing. The maximum similarity rate accepted is **30%**. Manuscripts which exceed these limits are analyzed in detail and if deemed necessary returned to the authors for revision or correction, if not they could be rejected to be published if any plagiarism or unethical behavior is detected.

Following are some of the behaviors which are accepted as unethical:

- Indicating individuals who have not intellectually contributed to the manuscripts as authors.
- Not indicating individuals who have intellectually contributed to the manuscripts as authors.
- Not indicating that a manuscript was produced from author's graduate thesis/dissertation or that the manuscript included was produced from a project's data.
- Salami slicing, producing more than one article from a single study.
- Not declaring conflicting interests or relations in the manuscripts submitted.
- Unveiling double blind process.

AUTHOR GUIDELINES

INSTRUCTION FOR AUTHORS

The authors are cordially invited to submit significant new findings of their research work papers in word and pdf formats to the journal office via online submission or e-mail: jsp@ratingacademy.com.tr along with a JSP cover letter. The journal will cover the topics related to the fields of **basic sciences, engineering, natural sciences and health sciences**. All articles submitted for publication are evaluated by the editor-in-chief, field editor, editorial board and referees. The original research papers, technical notes, letter to the editor, debates, case presentations and reviews only in *English* are published in the journal.

The editorial board of JSP welcomes original novel contributions and reviews in word format. By submission of a manuscript an author certifies that the work is original and is not being considered simultaneously by other journals. All articles are subjected to critical reviews by referees.

Cover Letter

The cover letter should be prepared and sent to the Editor-in-Chief via e-mail.

Software and Format

- ❖ Regular paper should describe new and carefully confirmed findings, and experimental procedures should be given in sufficient detail for others to verify the work. The length of a full paper should be the minimum required to describe and interpret the work clearly. The total length of any manuscript submitted must not exceed **25 pages**.
- ❖ Papers should be written in clear, concise language (*English*).
- ❖ Manuscripts should be prepared in English using a word processor. MS Word for Windows and docfiles are preferred. Manuscripts may be prepared with other software provided that the full document (with figures, schemes and tables inserted into the text) is exported to a MS Word format for submission.
- ❖ Do not use desktop publishing software such as Aldus PageMaker or Quark XPress. If you have prepared your manuscript with one of these programs, export the text to a word processing format.
- ❖ Times New Roman font is preferred. The font size should be 12 PT.
- ❖ The first line of the paragraph should be shifted by 1,25 cm from the left margin. Paragraph spacing after a single paragraph (6 nk) should be given.
- ❖ Papers should be single spaced with ample margin. The page setup is A4 size.
- ❖ The manuscript, which does not show the names of the authors, must include the followings: Title, Abstract, Keywords under the abstract, introduction, main text, conclusion, references and appendix.
- ❖ No footer, header or page numbers required.
- ❖ Name each file with your last name of the first author.

1. Title of the paper: The title must be concise and informative and should not exceed the 60 characters (12-15 words) including spaces (with key words appropriate for retrieval purposes) and provide peer readers with a quick overview of the paper contents. Avoid abbreviations and formulae where possible.

Title of the paper set in the midst, should be written in bold, in Times New Roman 12 font size and 1,5 spaced.

Headings and subheadings must be numbered 2., 2.1., 2.1.1. as etc decimally with bold letters. All headings should be written in bold but only the first letters of the subtitles should be capital. Spacing before and after a heading (6 nk) should be given.

2. Name of the author(s) with titles and the name and address of the institution where the work was done must be given. Provide, also, with the e-mail address of first and/or the corresponding author so that an immediate communication with the editor is possible. But these are not shown on the manuscript. They must be registered to the system while uploading the manuscript and indicated in the cover letter.

3. Abstracts and Key Words: All papers must have an abstract not more than 300 words of clear, informative and giving significant objectives, methodology, results and conclusion in the paper. Between **3** and **6** key words must be provided for the purpose of indexing and information retrieval. Abstract and key words must be written in Times New Roman 11 font size and single spaced. It also should be in *italic letters*. Presentation of numerical results should be avoided as far as possible in the abstract.

4. Text: The paper must be divided into sections and subheadings starting preferably with Introduction and ending with Conclusion followed by Acknowledgement.

5. Tables: Tables should be single spaced. The tables should be kept to a minimum and be designed to be as simple as possible. Tables are to be typed single-spaced throughout, including headings and footnotes. Each table should be numbered consecutively in Arabic numerals and supplied with a heading and a legend. The title should be placed at the top. Explanatory information and experimental conditions should be given as a note at the bottom. Explanatory information and experimental conditions should be given as a note at the bottom of the columns. Tables should be self-explanatory without reference to the text. The same data should not be presented in both table and graph form or repeated in the text.

The headlines of the tables must be written in Times New Roman 12 font and with bold letters. References for the tables (figure or graph) must be below the table (figure or graph) with a font size of 11 font.

6. Figure: Illustrations must be numbered consecutively in Arabic numerals. They should be cited in the text as Figure 1, Figure 2, and so on. Begin each legend with a title at the bottom of the illustration and include sufficient description so that the figure is understandable without reading the text of the manuscript. Graphics should be prepared using applications capable of generating high resolution (300 dpi) JPEG before pasting in the Microsoft Word manuscript file.

The headlines of the figures must be written in Times New Roman 12 font and with bond letters. References for the tables (figure of graph) must be below the table (figure or graph) with a font size of 11 font.

7.Citations: All papers cited in the text, tables, and figures must be included in the references and all papers cited the references section should be cited in the text. Authors should monitor references at all phases of manuscript preparation. References in the text should be cited by author and year. Single author: Clark (2004) or (Clark, 2004). Two authors: Gupta and Clark (2015) or (Gupta and Clark, 2012). More than two authors: Gupta *et al.* (2015) or (Gupta *et al.*, 2015). In the event that an author cited has had two or more works published during the same year, the reference, both in the text and in the reference list, should be identified by a lower case letter like a and b after the date to distinguish the works.

8.References: References should be listed at the end of the paper in alphabetical order. Articles in preparation or articles submitted for publication, unpublished observations, personal communications, etc. should not be included in the reference list. Journal names are abbreviated according to Biological Abstracts and correctly format the references of your paper. Authors are fully responsible for the accuracy of the references. All the references must be in the following order.

Books:

SURNAME, NAME, Publication Year, *Name of Book*, Publishing, Place of Publication, ISBN.

MERCER, P.A. and SMITH, G., 1993, *Private Viewdata in the UK*, 2

Journals:

SURNAME, NAME, Publication Year, Name of Article, *Name of Journal*, Volume Number and Page Numbers.

EVANS, W.A., 1994, Approaches to Intelligent Information Retrieval, *Information Processing and Management*, 7 (2), 147-168.

Conferences:

SURNAME, NAME, Publication Year, Name of Report, *Name of Conference Bulletin*, Date and Conference Place, Place of Publication: Publishing, Page Numbers

SILVER, K., 1991, Electronic Mail: The New Way to Communicate, *9th International Online Information Meeting*, 3-5 December 1990, London, Oxford: Learned Information, 323-330.

Thesis:

SURNAME, NAME , Publication Year, Name of Thesis, Master's Degree/Doctorate, Name of Institute

AGUTTER, A.J., 1995, The Linguistic Significance of Current British Slang, Thesis (PhD), Edinburgh University.

Maps:

SURNAME, NAME , Publication Year, Title, Scale, Place of Publication: Publishing.

MASON, James, 1832, Map of The Countries Lying Between Spain and India, 1:8.000.000, London: Ordnance Survey.

Web Pages:

SURNAME, NAME, Year, Title [online], (Edition), Place of Publication , Web address: URL

HOLLAND, M., 2002, Guide to Citing Internet Sources [online], Poole, Bournemouth University, http://www.bournemouth.ac.uk/library/using/guide_to_citing_internet_sourc.html, [Date Accessed: 4 November 2002].

Identification: It is particularly important that the authors get their biological material authentically identified and quote at least once, on its first citation in the paper, the technical name of the species concerned in full preceded by its popular name where possible, e.g. The water bug *Sphaerodema rusticum* (Fabr). Genus and species names should be italic.

Footnotes: Footnotes should be avoided as far as possible. Essential footnotes may, however, be indicated by superscribed reference marks (*, †, ‡,).

Statement of human and animal rights

When reporting experiments on human subjects, authors should indicate whether the procedures followed were in accordance with the ethical standards of the responsible committee on human experimentation (institutional and national) and with the Helsinki Declaration of 1975 (revised in 2000). If doubt exists whether the research was conducted in accordance with the Helsinki Declaration, the authors must explain the rationale for their approach, and demonstrate that the institutional review body explicitly approved the doubtful aspects of the study. When reporting experiments on animals, authors should be asked to indicate whether the institutional and national guide for the care and use of laboratory animals was followed.

Statement of Informed Consent

Patients have a right to privacy that should not be infringed without informed consent. Identifying information, including patients names, initials, or hospital numbers, should not be published in written descriptions, photographs, and pedigrees unless the information is essential for scientific purposes and the patient (or parent or guardian)

gives written informed consent for publication. Informed consent for this purpose requires that a patient who is identifiable be shown the manuscript to be published. Authors should identify Individuals who provide writing assistance and disclose the funding source for this assistance.

Identifying details should be omitted if they are not essential. Complete anonymity is difficult to achieve, however, and informed consent should be obtained if there is any doubt. For example, masking the eye region in photographs of patients is inadequate protection of anonymity. If identifying characteristics are altered to protect anonymity, such as in genetic pedigrees, authors should provide assurance that alterations do not distort scientific meaning and editors should so note.

Submission: The manuscript should be submitted preferably by our online manuscript submission centre in the following URL: <https://www.ratingacademy.com.tr/jsp/> or as e-mail attachment to the Editorial Office via: info@ratingacademy.com.tr . All contacts shall be by e-mail. All the corresponding authors should have an e-mail id. All submissions will be acknowledged within a short time.

Brief checklist for submission.

1. Have you provided a Cover Letter?
2. Have you provided the informations of the correponding author and the other authors to the system?
3. Have you provided an Abstract of 300 words ?
4. Have you provided Keywords?
5. Are your Tables denoted by Arabic numerals, and are they in order as cited in the text?
6. Are your Figures denoted by Arabic numerals, and are they in order as cited in the text?
7. Are your References cited in the required format of the Journal?
8. Is institutional approval number provided for the mammalian animal used for the experiment?
9. Have you obtained permission and submitted documentation for all Personal Communications cited?

Technical Notes: Technical notes are shorter than research articles and may be used to describe a new methodology or to present results from new techniques or equipment. A technical note should not exceed 20 pages with no more than 5 figures and tables. These rules are valid for debates and case presentations.

Proofs and Reprints: Electronic proofs will be sent (e-mail attachment) to the corresponding author as a PDF file. Corrections should be restricted to typesetting errors. Authors are advised to check their proofs very carefully before return, since inclusion of late corrections cannot be acceptable Corrected proofs are to be returned to the publishers.

Page proofs are considered to be the final version of the manuscript. The Editorial Board reserves the right to make changes like typographical or minor clerical errors if necessary in the research articles. No changes will be made in the manuscript at the proof stage.

Authors will have free electronic access to the full text (PDF) of the article. Authors can freely download the PDF file from which they can print unlimited copies of their articles.

The Editorial Board reserves the right to make changes if necessary mainly to improve the quality of the paper.

The responsibility of the contents rests upon the authors and not upon the publisher.

Authors are requested to prepare the manuscript according to our journal “Instructions for authors” guidelines.

Subscription Rates and Terms: Those who are interested to obtain the electronic copy of the JSP, he/she can download it free of charge.

ABSTRACTING & INDEXING

ERIHPLUS

Google Scholar

ProQuest

PKP Index

DOI

Base

SOBIAD

iThenticate

Academic Resource Index: ResearchBib

Academic Journal Index (AJI)

Academic Keys

AcademicKeys

Bielefeld Academic Search Engine: BASE

Cite Factor

CNKI Scholar

Cosmos Impact Factor

CrossRef

DIIF

Directory of Indexing and Impact Factor (DIIF)

Directory of Research Journals Indexing (DRJI)

Elektronische Zeitschriftenbibliothek EZB

Euro Pub

General Impact Factor

Geneva Foundation for Medical Education and Research (GFMER)

German National Library of Science and Technology (TIB)

German Union Catalogue of Serials (ZDB)

Harvard Library HOLLIS

IARC(JCRR): Journal Impact Factor

ICMJE

Idealonline

Infobase Index

International Institute Of Organized Research (I2OR)

International Services For Impact Factor And Indexing (ISIFI)

International Institute of Organized Research (I2OR)

ISRA:Journal-Impact-Factor (JIF)

Journal Index

JournalPark

MIAR

OALib

OCLC WorldCat

PAK Academic Search (Pending)

PoolText

ProQuest Biological Science Database

ProQuest Central

ProQuest SciTech Premium Collection

ProQuest Natural Science Collection

ProQuest Turkey Database

ROOT Indexing

SCIWIN (Scientific World Index)

Scientific Indexing Services

Scilit

Scipio

Scopemed

Semantic Scholar

SI Factor

Society of Economics and Development

Sparc Indexing

Turkish JournalPark

Türk Eğitim İndeksi

World Wide Science

ZDB-ID

JOURNAL OF
SCIENTIFIC
PERSPECTIVES

JSP

International Peer-Reviewed Journal

Volume: 4

Issue: 2

April 2020

CONTENTS

Basic Sciences and Engineering

ROBUST SIEVE ANALYSIS USING SIEVE-BY-SIEVE METHOD

Kouroskh KHADIVI & Shahab HEJRI & Shapour VOSOUGHI83-98

**TEACHING AND LEARNING OF INDUSTRIAL CYBER SECURITY TECHNOLOGIES
BASED ON PHOENIX CONTACT COMPANY WIRELESS EQUIPMENT**

Vladlen SHAPO & Maksym LEVINSKYI & Valeriy VOLOVSHCHYKOV99-110

**A CRITICAL APPROACH TO THE PARTICLE SWARM OPTIMIZATION METHOD FOR
FINDING MAXIMUM POINTS**

Mine SERTSÖZ & Mehmet FİDAN 111-122

SMART FARMING- PRECISION AGRICULTURE TECHNOLOGIES AND PRACTICES	
<i>Aylin KIRKAYA</i>	123-136
AN EVALUATION OF A CONSTRAINED MULTI-OBJECTIVE GENETIC ALGORITHM	
<i>Youssef ALIOUI & Reşat ACAR</i>	137-146
THE EFFECT OF THERMAL POWER PLANT FLY ASH IN GRANITE BODY ON MICROSTRUCTURE AND TECHNICAL PROPERTIES	
<i>Savaş ELMAS</i>	147-156

Natural Sciences

THE EFFECTS OF POTASSIUM APPLICATIONS ON DROUGHT STRESS IN SUGAR BEET: PART I. SUGAR BEET QUALITY COMPONENTS	
<i>Gizem AKSU & Hamit ALTAY</i>	157-168
EFFECTS OF GINGER EXTRACTS ON TOTAL PROTEIN AMOUNT AND PEROXIDASE ACTIVITY IN SOLANUM LYCOPERSICUM L.	
<i>Zeynep ÖZCEYLAN & Cüneyt AKI</i>	169-176

Journal of Scientific Perspectives

Volume 4, Issue 2, Year 2020, pp. 83-98

E - ISSN: 2587-3008

URL: <https://ratingacademy.com.tr/ojs/index.php/jsp>

DOI: <https://doi.org/10.26900/jsp.4.007>

Research Article

ROBUST SIEVE ANALYSIS USING SIEVE-BY-SIEVE METHOD

Kouros KHADIVI * & Shahab HEJRI** & Shapour VOSOUGHI***

** Senior Reservoir Engineer & Modeler, (Tehran Energy Consultants (TEC),
Iran, Islamic Republic of, e-mail: khadiv@gmail.com
ORCID: <https://orcid.org/0000-0002-9495-6163>*

*** Senior Upstream Advisor, Petran Company,
Iran, Islamic Republic of, e-mail: hejrishahab@gmail.com
ORCID: <https://orcid.org/0000-0002-6859-0532>*

**** Professor of Chemical and Petroleum Engineering, Kansas University
United States, e-mail: shapour@ku.edu
ORCID: <https://orcid.org/0000-0002-6234-2175>*

Received: 3 November 2019, Accepted: 23 April 2020

ABSTRACT

Distribution of size of sand grains is an important factor in characterization of unconsolidated reservoirs as well as designing sand control devices. In practice, sand grains are passed through a set of known mesh sizes by mechanical vibration and for a fixed period then the weight of sediments retained on each sieve are measured and converted into the percentage of the total sediment (PTS). This procedure is applied to all core samples and the resulted PTS data are used for characterizing grain size distribution using one of the sieve analysis procedures. The core-by-core method, for example, is one of the conventional methods that PTS data from each core sample are used individually to estimate mean, sorting and other dependent parameters to grain size distribution. In this method, applying a robust statistical method to integrate all PTS data and picking out the most probable size from all cores is a challenge.

A new approach is introduced in this paper as sieve-by-sieve method, whereby the grain weight distribution data are classified based on mesh sizes (as bins) and the most probable size in each class is picked out among all cores directly and without any manipulation or averaging.

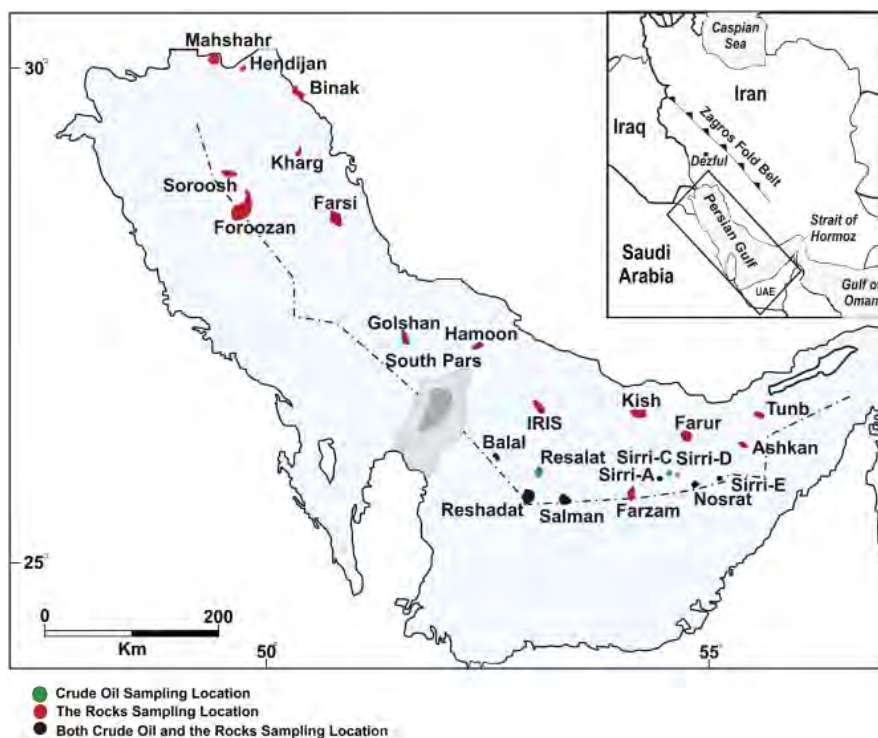
In this paper, the performance of both methods are compared in a homogeneous media and a heterogeneous media. In a homogeneous media, both methods provide comparable results. However, in a heterogeneous media, the core-by-core provides too many distributions which sometimes are not conclusive but the sieve-by-sieve provides the profiles of minimum and maximum weight of retained grains, which facilitates picking out the most probable size among all cores.

Keywords: *Sieve analysis, core-by-core method, sieve-by-sieve method, mean, sorting, the most probable size.*

1. INTRODUCTION

Burgan Formation is a prolific oil reservoir in Foroozan field in the North West of Persian Gulf (Figure 1). The main reservoirs are Burgan A and Burgan B. It is a siliciclastic reservoir and a member of Lower Cretaceous period. The offshore oil reservoir from Burgan formation has the same geologic characteristics of well-studied formation in the Persian Gulf region common with Kuwait, Saudi Arabia and some other oil-rich countries of the region (Ahlbrandt et al. 2000; Stromenger, et al. 2002; Al-Ajmi and Azim 2003; Mehrabi et al. 2019). The Burgan sands are believed to have been deposited as delta sediments. The Burgan source area began rising during the later Upper Shuaiba time, silt and shale with some occasional thin carbonate beds are inter-bedded over the field and surrounding areas. Due to the rise of the source area at the beginning of Burgan B deposition, a thick layer of sand was deposited, probably as a delta of numerous streams.

Figure 1: Location map of Foroozan Field in Persian Gulf (from Sadat and Rabbani 2015).



During Burgan A sand deposition no regression of the sea had happened, but further transgression occurred which resulted in the deposition of silts and clay particles. Even traces of carbonates were deposited during Burgan A sand depositional period. An interbedded sequence of sand, silt and clay particles was the product of rises and falls of the sea during Burgan A time. Some of the beds cover a wide area but some others are very limited in their lateral extent over the field. The deposition of Burgan A was ended with a major transgression of the sea and with the deposition of limestone beds on top of the Burgan A sand known as Dair Limestone. The Dair Limestone member covers the entire area in the field and surrounding areas and it indicates the end of Burgan deposition.

The Burgan is further defined as a sequence of fairly well sorted, medium to coarse-grained sands, usually loosely packed, and with interbeds of shale and silt shale and abundant amber and bituminous matter. The Burgan sandstone is cemented by carbonate and clay. The upper sand stringers in Burgan A are very fine grained sand (silt size) and generally have poorer rock characteristics. The sand grain size generally becomes coarser and exhibits better porosity

and permeability towards the base of Burgan A. The basal portion of the Burgan (Burgan B) consists of medium to coarse, unconsolidated sandstone. Since the Burgan B sand is generally clean and has very coarse grains (it resembles beach sand in most cases), it has on the average higher porosity and permeability than the Burgan A.

Geological study of Burgan reservoirs shows that there are several unconsolidated sand layers in these reservoirs (Mehrabi et al. 2019). A common problem in unconsolidated reservoirs like Burgan reservoir is sand migration to the wellbore (Al-Awad et al. 1999; Zivar et al. 2019). In fact, it is because of poor cementation between sand grains whereby sand grains can slip and move over each other and migrate from sand body to the wellbore then travel through the production tubing. Sand production is a harmful phenomenon because of severe erosion through production tubing, wellhead, choke, and clogging of production lines. In addition, it causes premature water breakthrough in waterflooding process (Nassir et al. 2015). The visual observation of cores and daily production reports of nearby field confirmed this problem. Thus, it was considered in the mitigation program and designing well completion for new wells (Khadivi and Vossoughi 2005). Slotted liner and Screener are two types of sand control devices, which restrict sand migration and settle them beyond the casing (Dong 2016; Shahsavari and Khamnehchi 2018; Mahmud et al. 2019; Wang et al. 2019).

Design of mesh size of a sand control device (i.e. gravel pack, screener or slotted liner) requires information about the most probable size of sand grains. There are several techniques for selecting the mesh size of a sand control device. The most widely used sizing criterion provides sand control when the median grain size of the gravel-pack sand, D_{50} , is no more than six times larger than the median grain size of the formation sand, d_{50} (Penberthy and Shaughnessy, 1992). In the other side, the size of the holes can be half of the smallest grain diameter but should not be smaller than 70% of the smallest grain diameter as this design becomes conservative and restricts productivity. Therefore, mesh size impacts significantly on the economic and productivity of wells. As such, our goals for this study are,

- To find the variability scheme through these formations and relate it to sand size distribution and,
- To find the most probable size of sand grains among all cores to be used for robust design of sand control devices.

In order to address above objectives, sieve analysis is used as a tool to obtain distribution of size of sand grains, which is an important factor in characterization of unconsolidated reservoirs as well as designing sand control devices.

2. SIEVE ANALYSIS

Grain size is one of most fundamental property of sediment particles, which influences on the entraining, transporting and depositing of sand particles. Sieve analysis is a method to obtain the dominant grain size of sediment particles (Folk and Ward, 1957). Sand grain sizes are most generally measured by sieving. The basic principle of this technique is as follows (ASTM and AASHTO) whereby a sand sample of known weight is passed through a set of sieves of known mesh sizes. The sieves are arranged in downward decreasing mesh diameters. The sieves are mechanically vibrated for a fixed period. The weight of sediments retained on each sieve is measured and converted into the percentage of the total sediment (PTS). The percentage of the retained sample in every stage are added with the previous stage to obtain a new parameter named Cumulative Percentage of the Total Sediment (CPTS). This procedure is applied to every core sample and reported individually. This method is quick and sufficiently accurate for most purposes.

An important objective to conduct sieve analysis is to obtain sorting or the degree of scatterness. Sorting is tendency for the grains to fall in one class of grain size (see Appendix for formula). Cumulative curve is a useful presentation of data because many sample curves can be plotted on the same graph and differences in sorting become apparent. The closer a curve approaches the vertical the better sorted it is, as a major percentage of sediment occurs in one class. Significant percentages of coarse and fine end-members show up as horizontal limbs at the ends of the curve. Sorting can be expressed by statistical methods as well. The simplest of these is the measurement of the central tendency of which there are three commonly used parameters: median, mode, and mean. The median grain size is that which separates 50% of the sample from the other; the median is the 50 percentile. The mode is the largest class interval. The mean is variously defined, but a common formula is the average of the 25 and 75 percentile.

2.1 Conventional Sieve Analysis: Core-by-Core Method

Grain size distribution is normally investigated by sieve analysis based on statistical parameters and probability of occurrence for each core plug (McGlinchey Donald 2005). A conventional method of sieve analysis is based on core-by-core analysis. PTS data are used to estimate dominant size of sands, which potentially can migrate from the sand bodies to the wellbore. Statistical methods are applied to every single core data to acquire a measure of central tendency (including median, mode, and mean); a measure of the degree of scatterness or sorting; kurtosis, the degree of peakedness; and skewness, the lop-sidedness of the curve. Various formulae have been defined for these parameters (Folk and Ward, 1957). Eventually, statistical analysis is performed on the grain weight distribution of cores then the most probable size is picked out from the whole core data (Fuller et al. 2019). However, applying a robust statistical method to integrate all PTS data and picking out the most probable size from all cores is a challenge. In the other words, PTS data cannot be added or averaged because they are ratio numbers and have been resulted from different references. However, this method is simple to apply in homogenous reservoir where distribution is like a unimodal distribution (e.g. clean sand reservoirs) but it is difficult to get conclusive results in the heterogeneous reservoirs (e.g. shaly sandstone) where distribution is a kind of bimodal distributions.

In summary, lack of a robust averaging method over PTS data and handling variability of grains size are two shortcomings of the core-by-core method. To address above challenges, a new approach is presented in the next section whereby variability of grain size is incorporated into the averaging process simultaneously.

2.2 New Sieve Analysis Method: Sieve-by-Sieve Method

Variability of the grains size across the perforated interval is a challenge which can be addressed by studying depositional environment. The weighted average method could be a solution to integrate all data; however, lack of relevant data to account for the representative volumes of sand bodies is a new challenge. Another solution for this problem would be developing an integrated method through scaling up from core-level to whole-core-level while heterogeneity of grains size is preserved. The benefit of this method is applying sieve analysis once and just on the whole core instead of multiple analysis on the entire core samples. In the other words, instead of multiple averaging on the core data to achieve a unique value as the most probable grain size, cores are combining together and grain size distribution is analyzed once on the whole core. Although this idea may not be practical in the lab but it is possible by the mathematical calculation and applying a novel method of sieve-by-sieve method. All cores indeed are assumed parts of a whole core, which have been sampled and sieved in several steps. In addition, contrary to the core-by-core method, which is based on PTS (ratios) data, the sieve-by-sieve method is based on the weight of retained grains, which is an addable parameter. In this method, the weight data are classified based on the mesh sizes (as bins). Such classification

allows us to compare the corresponding data of all cores and pick out the most probable size in each class directly without any manipulation or averaging. The sieve-by-sieve method is simple and robust because it does not use any complicated statistical calculation or averaging method.

3. RESULTS AND DISCUSSION

Among 200 core samples across Burgan formation, 17 core samples were selected for sieve analysis which 4 of them falls in the Burgan A and the rest (17 samples) from Burgan B (Nemati, et al., 2003). Cores have not been sampled across the reservoir sections consistently. Most of cores are from Burgan B and a few of them are from Burgan A. In addition, distribution of samples is not uniform. In Burgan B, samples have been taken more or less from the entire reservoir section; however, a few samples have been taken from top of Burgan A with no sample from the base of this reservoir. Inadequacy and non-uniformity of samples create uncertainties in representativeness of samples in Burgan A.

Conventional core analysis (CCAL) tests were undertaken to acquire grain density, porosity and permeability data. The CCAL results are discussed to better understand porous media then sieve data are examined using core-by-core and sieve-by-sieve methods to see the privilege of sieve-by-sieve methods against core-by-core method.

3.1 Conventional Core Analysis (CCAL)

Comparing average grain density data shows that the nature of both reservoirs predominantly is sand. An average grain density of 2.64 g/cc in Burgan A against 2.61 cc/gr in Burgan B confirms poor carbonate content and cementation in Burgan B.

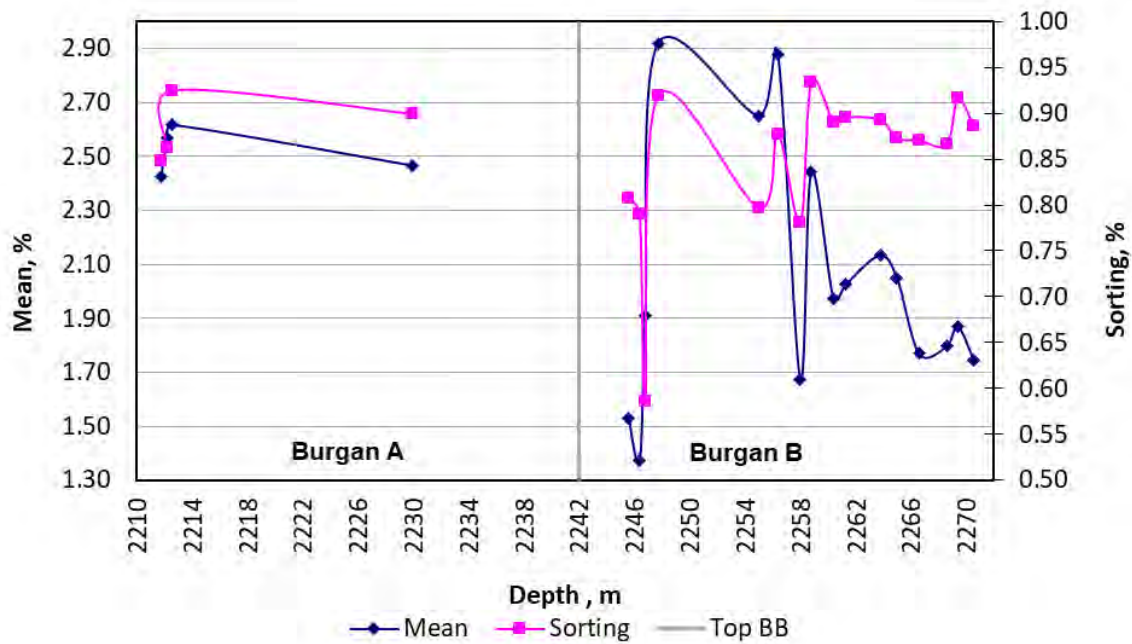
Figure 2 is an exhibition of sorting and mean of all core samples from Burgan A and Burgan B formations (see Appendix for formula). No significant correlation is seen between these two parameters.

As mentioned before, Burgan A is a sandstone formation mixed with shale, silt and bituminous matter, which have been cemented by carbonate and clay. However, the available mean and sorting data (4 samples) show minor variations in Burgan A, thus in any analysis based on such data, it is considered a homogenous reservoir. Burgan B, in contrast, consists of medium to coarse, unconsolidated sandstone and generally clean sands with higher porosity and permeability than Burgan A. However, variations of mean and sorting parameters in Burgan B are much wider than Burgan A, so in any analysis based on these data, Burgan B resemble a heterogeneous reservoir.

In the lower part of Burgan B, the mean profile decreases in a stepwise fashion. This is a typical representation of fining downward (or coarsening upward) behavior, which is common in the clastic reservoirs (Van Wagoner, et al., 1990; Emery and Myers, 1996).

The sorting remains almost constant at the base of Burgan B, which means in spite of decreasing grain sizes (or mean), the relative amount of different grain sizes (or sorting) remains relatively constant. Considering a high degree of sorting (0.9) in this zone, a high permeable zone in this zone is expected.

Figure 2: Comparing profiles “sorting” and “mean” with depth.



In order to investigate dependency of mean and sorting parameters with formation permeability, the profiles of permeability and mean are presented in Figure 3, while the profiles of permeability and sorting are presented in Figure 4. Permeability and sorting shows a better correlation than permeability and mean. Increasing permeability in the base of Burgan B is attributed to the well sorted grains, uniformity of clean sand grains and poor cementation factor.

Figure 3. The profiles of permeability and mean grain size with depth in Burgan A & B.

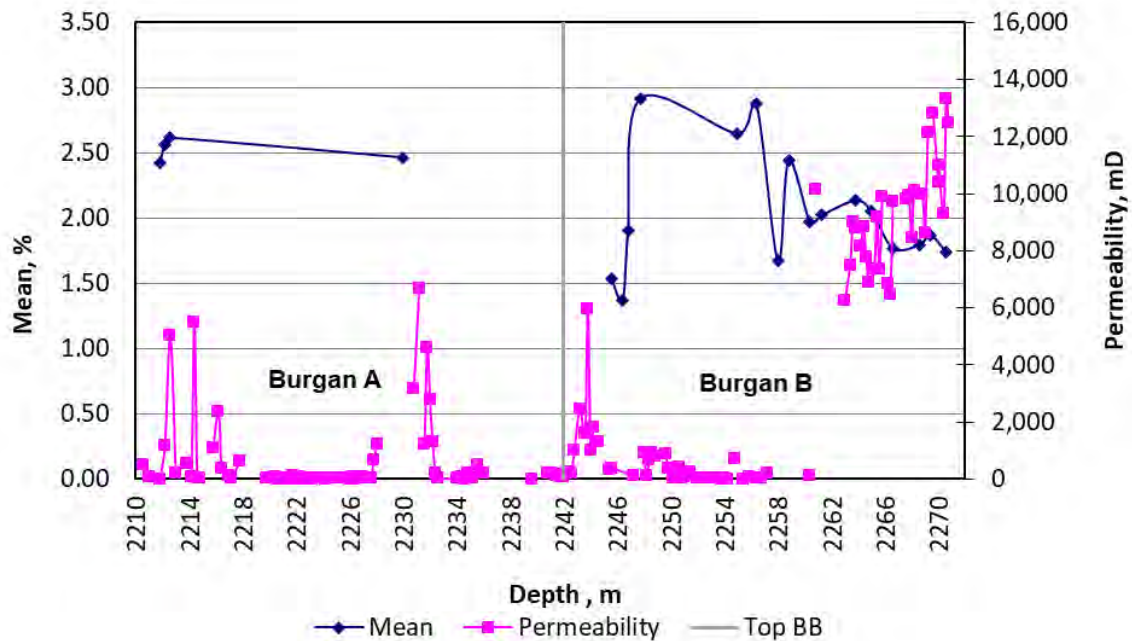
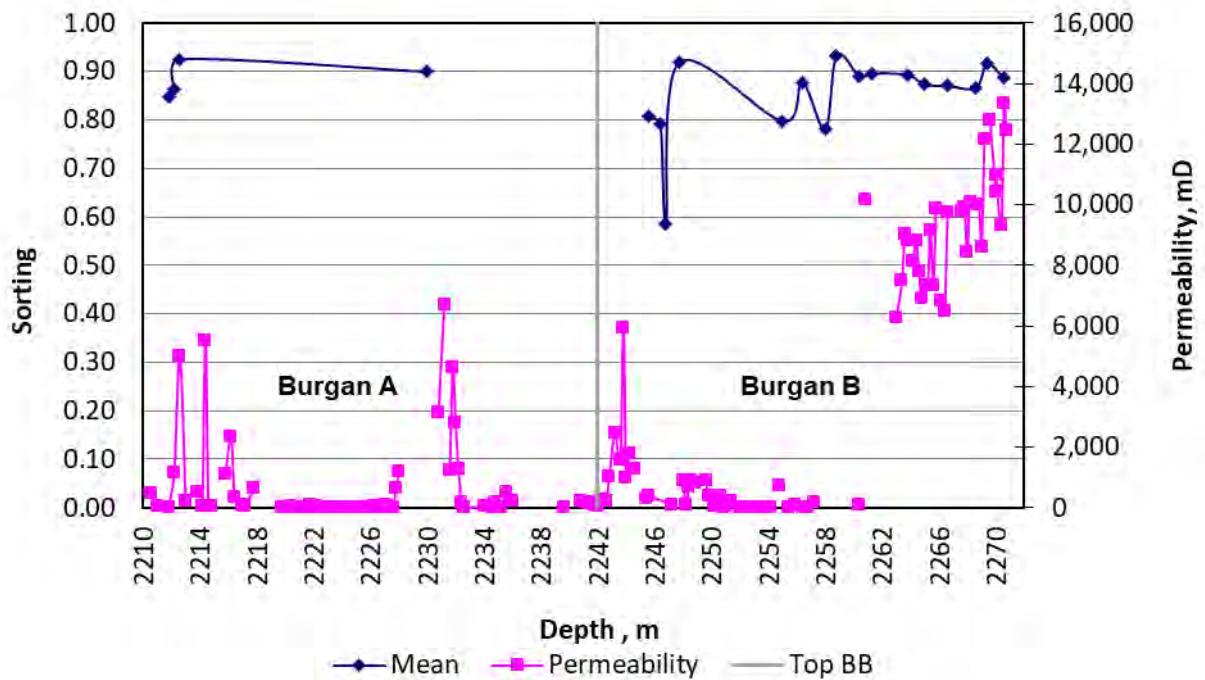


Figure 4: The profiles of permeability and Sorting with depth in Burgan A & B.



The profiles of mean and sorting are compared with porosity in Figures 5 and 6, respectively. Correlation of porosity and sorting specially in Burgan B is seen clearly in Figure 6; however, no correlation exists between porosity and mean grain size.

Figure 5: The profiles of porosity and mean grain size with depth in Burgan A & B.

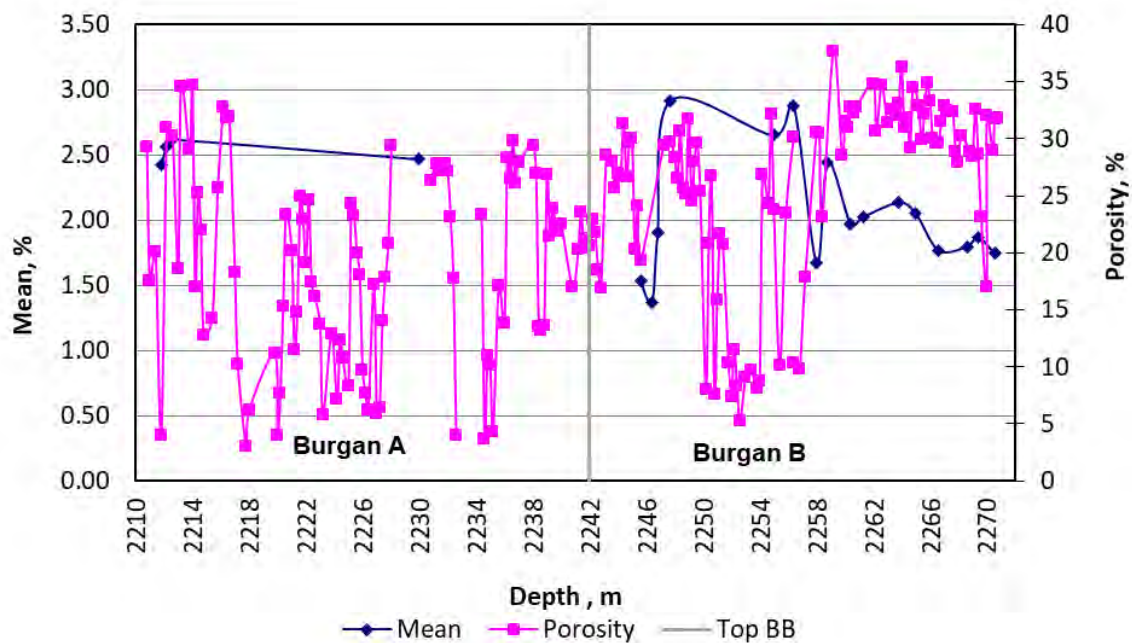
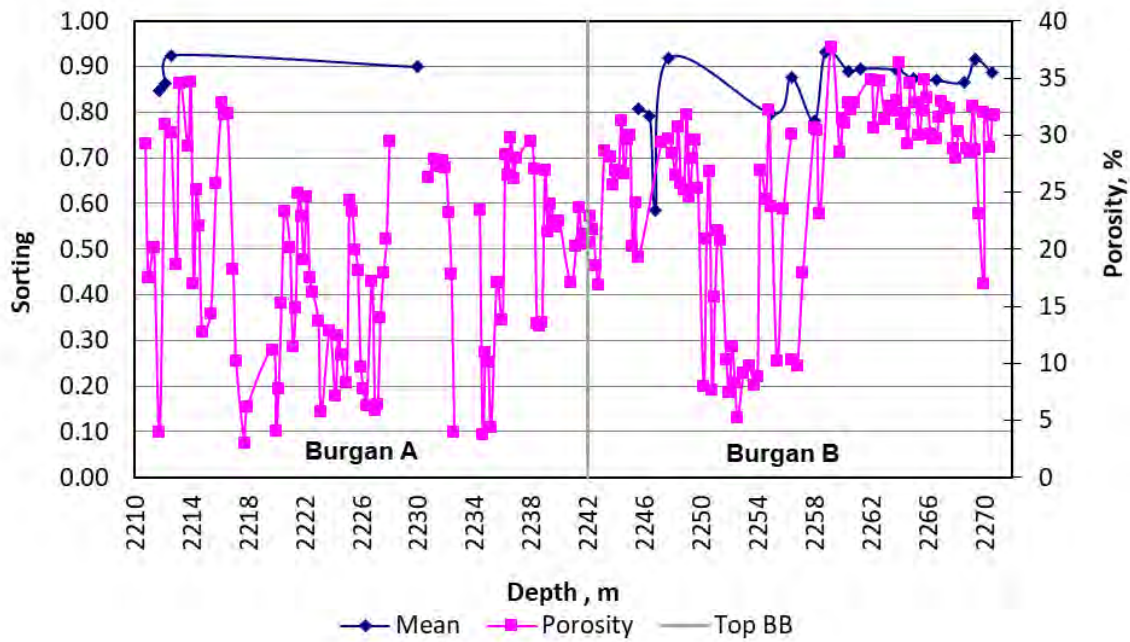
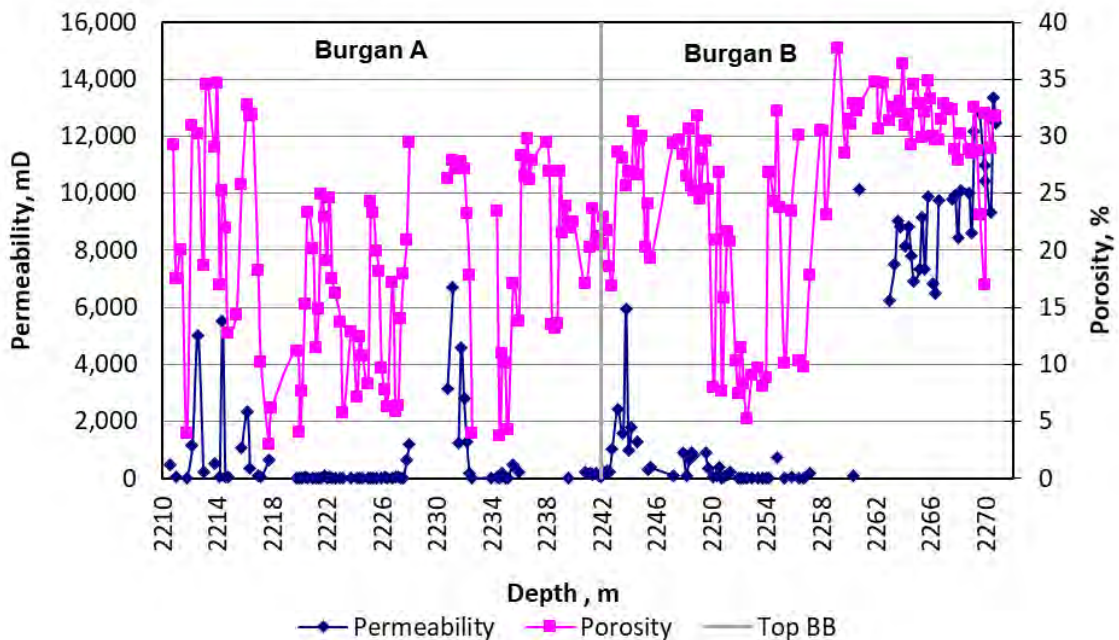


Figure 6: The profiles of porosity and sorting with depth in Burgan A & B.



As shown in Figure 7, a nice correlation is seen between porosity and permeability along the depth in Burgan A and B. This correlation is confirmed in the next cross plots as well. Figure 8 and Figure 9 show porosity-permeability cross plots in Burgan A and Burgan B reservoirs, respectively.

Figure 7: The profiles of porosity and permeability with depth in Burgan A & B.



Comparing permeability data and the fitted functions in both reservoirs (Figure 8 and 9) shows better rock quality (permeability) in Burgan B than Burgan A. This is confirmed by comparing the correlation coefficient (R^2 values) data as well, which is higher in Burgan B (Figure 9).

Figure 8: Cross plot of porosity-permeability in Burgan A Formation.

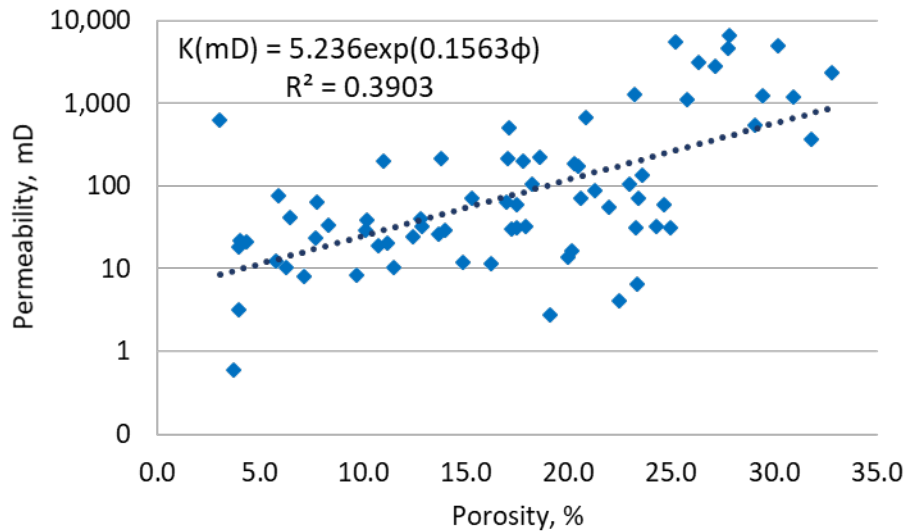
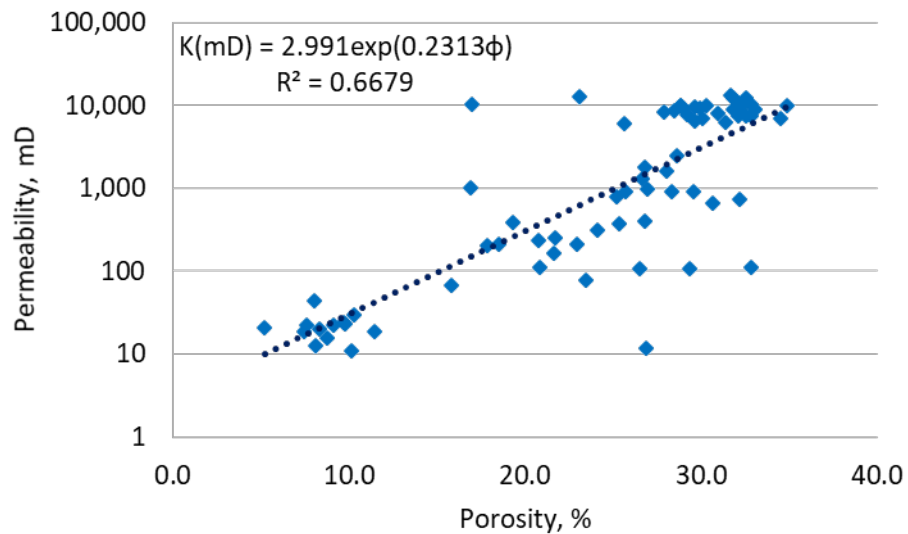


Figure 9: Cross plot of porosity-permeability in Burgan B Formation.



Improving permeability, porosity and sorting properties at the base of Burgan B (Figure 4 and Figure 6) attribute existence of a clean and loose sands with minimal cementation. This is an important conclusion as the most probable location of sand production is identified.

3.2 Sieve Analysis

Estimating dominant grain size is crucial for designing sand control devices. This requires integrating the most probable grain size of all core samples. Figure 10 presents distribution of grain sizes of 4 core samples from Burgan A. Figure 10 indeed is a representation of conventional sieve analysis using core-by-core method. Meanwhile, the weight of retained grains of all 4 core samples on every sieve are added together to obtain distribution of the

retained grain sizes using sieve-by-sieve method. Figure 11 presents minimum and maximum distributions of the weight of retained grains of all core samples using sieve-by-sieve method.

Figure 10: Conventional sieve analysis using Core-by-Core Method in Burgan A.

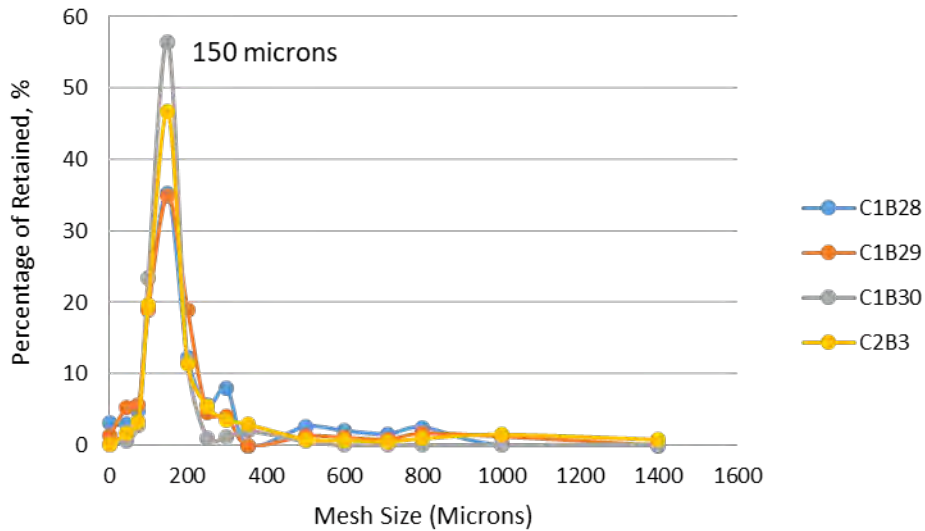


Figure 11: New sieve analysis method based on the Sieve-by-Sieve Method in Burgan A.

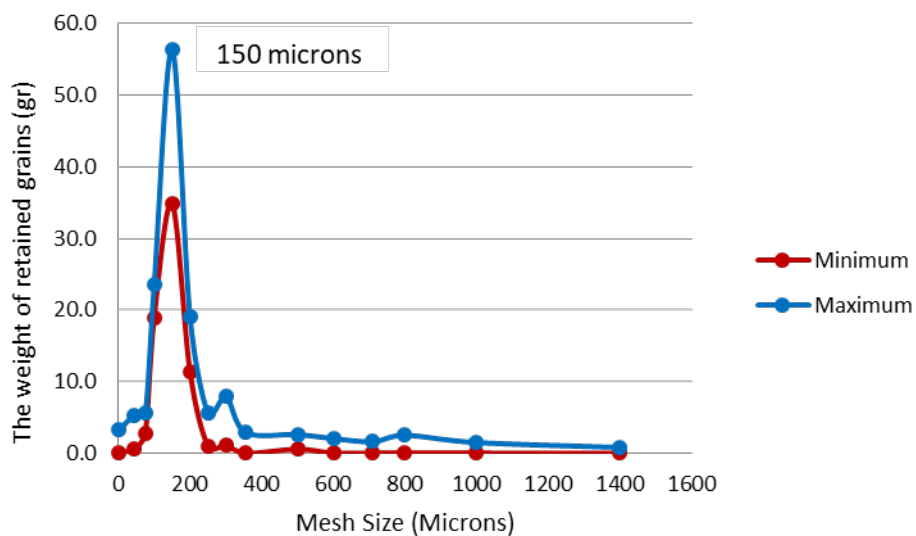


Figure 10 represents a strong leptokurtic histogram, which implies a very well sorted sand grain sizes in Burgan A. The most probable size based on this histogram is definitely 150 microns ($\phi=2.737$). Similar conclusion is derived from Figure 11 using sieve-by sieve method.

Figure 12 presents histograms of sand grains of 17 samples in Burgan B. Combining all histograms to get a representative distribution from all samples is not a straight forward task using core-by-core method. However, sieve-by-sieve method readily provides minimum and maximum distributions of the weight of the retained grains of all core samples as shown in

Figure 13. In fact, the sieve-by-sieve method exhibits a reliable averaging method to obtain a representative histogram of all samples. The shapes of distributions do not really look a unimodal histogram; thus, the mode of “maximum” histogram is chosen as the most probable size of sand grains in Burgan B, which is 100-150 microns ($\phi= 2.74-3.32$). Selecting a single mesh size among this range depends on the availability and economic of a sand control device as well as productivity of well.

Figure 12: Conventional sieve analysis using Core-by-Core Method in Burgan B.

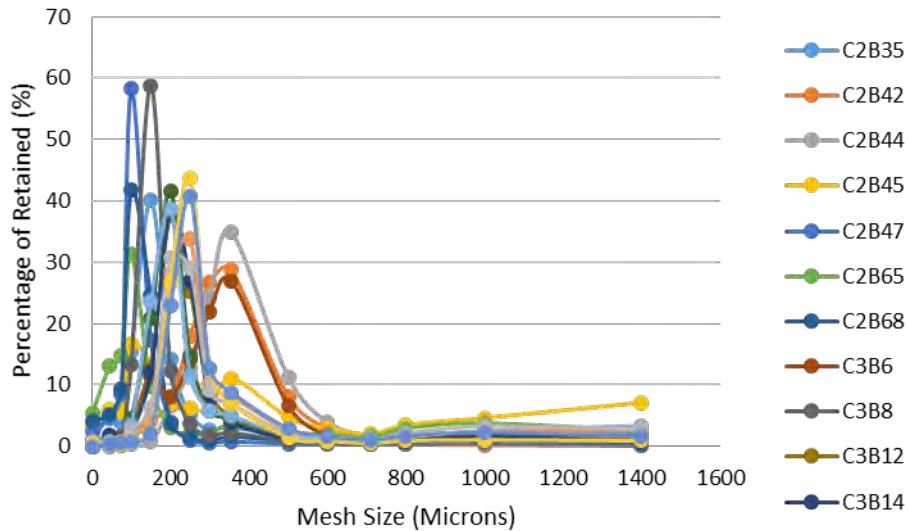
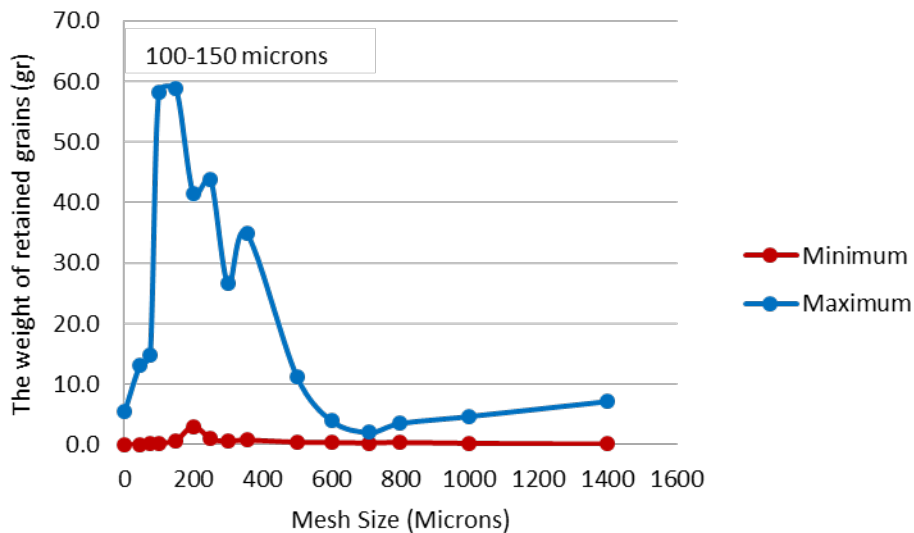


Figure 13: New sieve analysis method using Sieve-by-Sieve Method in Burgan B.



4. CONCLUSIONS

Sieve analysis is a useful and simple tool to characterize unconsolidated sandstone formations. Sorting and mean are two important parameters that can be integrated with CCAL data for reservoir characterization. Statistical parameters can also be used for determination of distribution of size of sand grains. All results provide an insight about possibility of sand migration and the most probable location of sand production.

The study presented here indicates that permeability and porosity exhibit some correlations with sorting but not with mean values of sand grain sizes. Conventional sieve analysis based on core-by-core method, attempts to obtain a mean sand size for the whole formation thickness. This method of study produces inherent uncertainties due to smoothing and reduction of data. A new approach was introduced in this paper as sieve-by-sieve method, whereby the weight of retained grains data were classified based on mesh sizes (as bins) and the most probable size in each class is picked out among all cores directly and without any manipulation or averaging.

As results, the performance of both methods were compared in Burgan A & B. The sorting data show less variability as seen in Burgan A (a homogeneous media) but they show some extends of variability in Burgan B (a heterogeneous media). Improving permeability, porosity and sorting properties at the base of Burgan B attribute existence of a clean and loose sands with minimal cementation. Both methods provide comparable results in terms of the most probable size of 150 microns ($\phi=2.737$) in Burgan A. The core-by-core provides too many distributions in Burgan B, which are not conclusive but the sieve-by-sieve provides the profiles of minimum and maximum weight of retained grains, which facilitate picking out the most probable size of 100-150 microns ($\phi= 2.74-3.32$).

5. Acknowledgements

We thank the management and director of petroleum department of PetroIran Development Company for permission to publish this paper.

REFERENCES

- AASHTO The Voice of Transportation. T0 27. (2006).
<https://store.transportation.org/?AspxAutoDetectCookieSupport=1>.
- ASTM International-Standards Worldwide. (2006). ASTM C136-06.
<https://www.astm.org/Standards/C136.htm>
- AHLBRANDT, T. S., POLLASTRO, R. M., KLETT, T. R., SCHENK, C. J., LINDQUIST, S. J., FOX, J. E., REGION 2 assessment summary – Middle East and North Africa, U.S. Geological Survey Digital Data Series 60, USGS, 2000.
- AL-AJMI, H., AND Z., AZIM, S. A (2003). Sequence stratigraphy, depositional environment and reservoir geology of Arabian Reservoirs in Kuwait, AAPG International Conference, Barcelona, Spain.
- AL-AWAD MUSAED N.J., EL-SAYED ABDEL-ALIM H., DESOUKY SAAD EL-DIN M., (1999). Factors Affecting Sand Production from Unconsolidated Sandstone Saudi Oil and Gas Reservoir, Journal of King Saud University - Engineering Sciences, Vol. 11, Issue 1, 1999, pp 151-172. [https://doi.org/10.1016/S1018-3639\(18\)30995-4](https://doi.org/10.1016/S1018-3639(18)30995-4)
- Dong Changyin, Zhang Qinghua, Gao Kaige, YangKangmin, Feng Xingwu, Zhou Chong, Petroleum Exploration and Development, Vol. 43, Issue 6, Dec 2016, pp 1082-1088.
[https://doi.org/10.1016/S1876-3804\(16\)30126-4](https://doi.org/10.1016/S1876-3804(16)30126-4)
- EMERY, D., and MYERS, K. Sequence Stratigraphy: Oxford, Blackwell Science, 297 p, 1996.
- FOLK, R. L. and WARD, W. C (1957). Brazos river bar [Texas]; a study in the significance of grain size parameters, J. of Sedimentary Research, v. 27, n. 1, p. 3-26.
- Fuller Michael, Palisch Terry, Fischer Christine, (2019). Sieve Distribution vs Sand Retention: The Impact of Mono-Sieved Gravel on Sand Control, SPE-196139-MS, presented in the SPE Annual Technical Conference and Exhibition, 30 September - 2 October, Calgary, Alberta, Canada.
- KHADIVI, K. and VOSSOUGHI, S., (2005). Foroozan Full Field Study, Final Report, Vol. II, Reservoir Characterization II, Document No. FE1000000RERS904201, PEDCO, NIOC.
- KRUMBEIN, W. C. (1934). Size frequency distributions of sediments. J. of Sedimentary Petrology. 2 (4). doi:10.1306/D4268EB9-2B26-11D7-8648000102C1865D.
- MAHMUD HISHAM B., VAN HONG, L., LESTARIONO, Y., 2019. Sand production: A smart control framework for risk mitigation, Petroleum, In Press.
<https://doi.org/10.1016/j.petlm.2019.04.002>
- MCGLINCHEY, D., (2005). Characterisation of bulk solids by, p231, CRC Press.
- MEHRABI, H., ESRAFILI-DIZAJI, B., HAJIKAZEMI, E., NOORI, B., MOHAMMAD-REZAEI, H., (2019). Reservoir characterization of the Burgan Formation in northwestern Persian Gulf, J. of Petroleum Science and Engineering, Vol 174, pp 328-350, March 2019. <https://doi.org/10.1016/j.petrol.2018.11.030>.
- NASSIR, M., WALTERS DALE, A., YALE DAVID P., CHIVVIS, R., TURAK, J., (2015). 3D Modeling of Sand Production in Waterflooding by Coupled Flow/ Geomechanical Numerical Solutions, IDARMA-2015-426, presented in 49th U.S. Rock Mechanics/Geomechanics Symposium, 28 June-1 July, San Francisco, California.
- NEMATI, M., ESFAHANI, M. R., HASHEMI, S. M., KAZEMZADEH, E., KAMALI, M. R. (2003). Sieve Analysis Results, Report No. 7745/5540, Research Institute of Petroleum Industry (RIPI), NIOC.

- PENBERTHY, W.L. Jr. and SHAUGHNESSY, C.M. (1992). Sand Control, Vol. 1, 11-17. Richardson, Texas: Monograph Series, SPE.
- SADAT, M. Z., & RABBANI, A. R., (2015). Organic geochemistry of crude oils and Cretaceous source rocks in the Iranian sector of the Persian Gulf: An oil–oil and oil–source rock correlation study, *International Journal of Coal Geology*, Vol 146, 1 July 2015, pp 118-144. <https://doi.org/10.1016/j.coal.2015.05.003>
- SHAHSAVARI, M. H., and KHAMEHCHI, E., (2018). Optimum selection of sand control method using a combination of MCDM and DOE techniques, *Journal of Petroleum Science and Engineering*, Vol. 171, Dec 2018, pp 229-241. <https://doi.org/10.1016/j.petrol.2018.07.036>
- STROHMENGER, C. J., DEMK, T. M., MITCHELL, J. C., PATTERSON, P. E., LEHMAN, P. J., AL-SAHLAN, G., AL-ENEZI, H., (2002). Sequence stratigraphy of the Burgan and Maudud formations (Lower Cretaceous, Kuwait): Reservoir distribution and quality in a carbonate-clastic transition, AAPG Annual Meeting, Houston, Texas.
- TRASK PD. (1932). *Origin and Environment of Source Sediments of Petroleum*. Gulf Publishing Company: Houston.
- VAN WAGONER, J. C., MITCHUM, R. M., CAMPION, K. M., and RAHMANIAN V. D., Siliciclastic sequence stratigraphy in well logs, cores, and outcrops: concepts for high-resolution correlation of time and facies: *AAPG Methods in Exploration* 7, 55 p, 1990.
- WANG, C., PANG, Y., MAHMOUDI, M., HAFTANI, M., SALIMI, M., FATTAHPOUR V., NOURIA A., (2019). *Journal of Petroleum Science and Engineering*, In Press, <https://doi.org/10.1016/j.petrol.2019.106608>
- ZIVAR, D., SHAD, S., FOROOZESH, J., SALMANPOUR, S., (2019). Experimental study of sand production and permeability enhancement of unconsolidated rocks under different stress conditions, *Journal of Petroleum Science and Engineering*, Vol. 181, Oct 2019, 106238. <https://doi.org/10.1016/j.petrol.2019.106238>.

Appendix

All equations used in this paper are presented here. Grain-size statistical parameters and graphic representations are given in phi units. The Krumbein (1934) proposed a logarithmic transformation of mesh size in millimeters into whole integers according to the following formula;

$$\phi = -\log_2(d), \tag{Eq. 1},$$

where d is the grain diameter in millimeters.

The statistical parameters like sorting and mean are defined based on the graphical cut off ϕ_{16} , ϕ_{25} , ϕ_{50} , ϕ_{75} and ϕ_{84} (Folk and Ward, 1957). A common formula to estimate sorting has been proposed by Trask (1932) as

$$Sorting = \sqrt{\phi_{25}/\phi_{75}}, \tag{Eq. 2}$$

where ϕ_{25} and ϕ_{75} represent the 25th and 75th percentiles of the grain size distribution in phi units. The mean parameter is calculated using the graphical cut off ϕ_{16} , ϕ_{50} , and ϕ_{84} (Folk and Ward, 1957),

$$Mean = \frac{\phi_{16} + \phi_{25} + \phi_{84}}{3}. \tag{Eq. 3}.$$

Nomenclature

PTS Percentage of the Total Sediment

CPTS Cumulative Percentage of the Total Sediment

d The grain diameter in millimeters

Greek letters

ϕ Phi, a logarithmic transformation of mesh size in millimetres

TEACHING AND LEARNING OF INDUSTRIAL CYBER SECURITY TECHNOLOGIES BASED ON PHOENIX CONTACT COMPANY WIRELESS EQUIPMENT

Vladlen SHAPO* & Maksym LEVINSKYI & Valeriy VOLOVSHCHYKOV*****

* National University "Odessa Maritime Academy",
UKRAINE, e-mail: vladlen.shapo@gmail.com
ORCID: <https://orcid.org/0000-0002-3921-4159>

** National University "Odessa Maritime Academy",
UKRAINE, e-mail: maxlevinskyi@gmail.com
ORCID: <https://orcid.org/0000-0002-6544-5110>

*** National Technical University "Kharkiv Polytechnic Institute",
UKRAINE, e-mail: valvol98@gmail.com
ORCID: <https://orcid.org/0000-0003-4454-2314>

Received: 6 January 2020, Accepted: 29 April 2020

ABSTRACT

Nowadays occurs a jump in approaches to maritime technical systems developing with implementation of Industry 4.0, IIoT, Shipping 4.0 concepts. Progress in wireless technologies allows to perform absolutely new engineering tasks. Maritime branch realizes digital transformation steps, which envisage creation of unmanned, autonomous and remote controlled ships. But such systems are vulnerable for external malicious intrusion. Thus it's necessary to deepen information technologies learning in maritime education in the following directions: IIoT, industrial wired and wireless data transfer technologies and hardware; satellite systems; big data, artificial intelligence, virtual and augmented reality; remote control; cyber security technologies. National University "Odessa Maritime Academy" participates in Trainings in Automation Technologies for Ukraine project. Obtained mobile equipment allows to study PcWorx and CoDeSys software for automation systems development (based on PLCs) and Profibus, ProfiNet, EtherCAT and wireless technologies. This base equipment may be supplemented by security firewalls.

Ways of modern technologies implementing in maritime branch are analyzed. Directions of deep studying are shown. Actuality and possibilities of cyber security technologies studying are highlighted. Approaches and technologies, successfully realized in education process and planned for future, are described.

Keywords: Industry 4.0, IIoT, Shipping 4.0, digital transformation, e-learning, industrial cyber security.

1. CONTEXT

Nowadays took place true jump in approaches to developing, control and exploitation of complex technical systems in maritime field with implementation of Industry 4.0, IIoT, Shipping 4.0, Ports 4.0 concepts. Thanks to progress in wireless and satellite technologies and mass appearance of embedded computer systems it's became possible to perform absolutely new engineering tasks and to create fully unmanned ships. Thus Unmanned Cargo Ship Development Alliance, Advanced Autonomous Waterborne Applications Initiative autonomous ship research project, Maritime Autonomous Surface Ships direction, Distributed Intelligent Vessel Components software, Digital, Internet, Materials & Engineering Co-Creation technical ecosystem, One Sea Ecosystem Alliance, Safer Vessel with Autonomous Navigation project are created. Currently maritime branch realizes digital transformation steps, which envisage creation of unmanned, autonomous and remote controlled ships by 2025 - 2035. But such complex systems are very vulnerable for external malicious intrusion. As a result huge financial losses, accidents and technological catastrophes are possible and already happened.

2. PURPOSE

Thus, on one side it's necessary to improve and deepen information technologies learning in maritime education institutions in the following directions: IIoT, industrial data transfer technologies, networks and protocols; wireless data transfer technologies; wide class computer control systems hardware; satellite data transfer systems, technologies and protocols; big data, artificial intellect, virtual and augmented reality technologies; remote control technologies and protocols; English language learning enhancement in general and IT terms particularly. On the other side, it's necessary to learn cyber security aspects, technologies and protocols. For realization of both these tasks it's necessary to use specific hardware facilities and e-learning technologies.

3. APPROACH

Theory of Automatic Control and Computing Machinery (TACCM) department of National University "Odessa Maritime Academy" (NUOMA) participates in EduNet (Education Network) program from 2011 (this program has unlimited duration) and participated in TATU (Trainings in Automation Technologies for Ukraine) project in 2013-2017. Formally TATU project had to last till December 2016 but because of unexpected bureaucratic problems at shipping of equipment from European Union to Ukraine was extended to the June 2017. Goals and some obtained results of TATU project are described in paper [1]. During TATU project realization learning books [2-4] in English and Russian languages are created by efforts of TACCM department of NUOMA collaborators, which have taken part in TATU project [2, 3], including participants from European and another Ukrainian universities [4]. Some specificities of maritime engineers education and training are touched on in papers [5, 6]. Some ways of enhancement of English language studying for maritime engineers are considered in paper [7]. Existing EduNet and TATU equipment allows to study the following software and technologies.

1. PcWorx (developer is Phoenix Contact company) and CODESYS (manufacturer independent software, developer is 3S-Smart Software Solutions company) are complex software integrated development environments (IDE) for development of automation and control systems based on programmable logic controllers.
2. Profibus, Profinet, EtherCAT and some another technologies/protocols.
3. Wireless data transfer technologies: IEEE 802.11 b/g/n and GSM standards.

During TATU project TACCM department of NUOMA obtained 4 sets of TATU Smart Lab (TSL) equipment. This is a flexibly configurable mobile set of devices for teaching modern automation technologies. It contains devices from Phoenix Contact, Siemens and Berghof manufacturers and was developed within the framework of Industry 4.0 (the fourth stage of industrial revolution). There are 3 hardware modules (independent portable boxes) in each TSL set: Profibus hardware module (HM), Profinet HM and EtherCAT and Process Modeling HM. Appearance and internal structure of Profibus HM presented in Figures 1, 2 accordingly.

Fig. 1. Appearance of TSL PROFIBUS hardware module

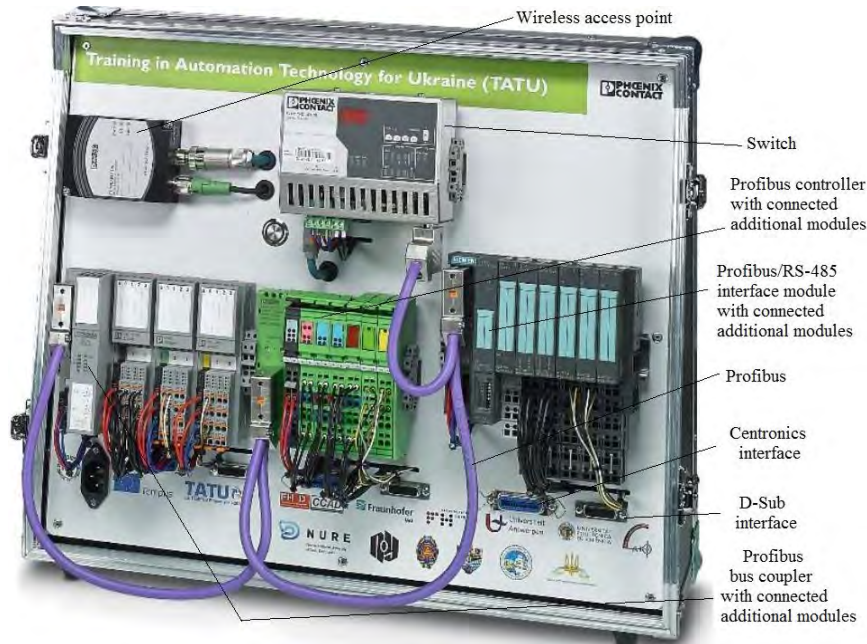
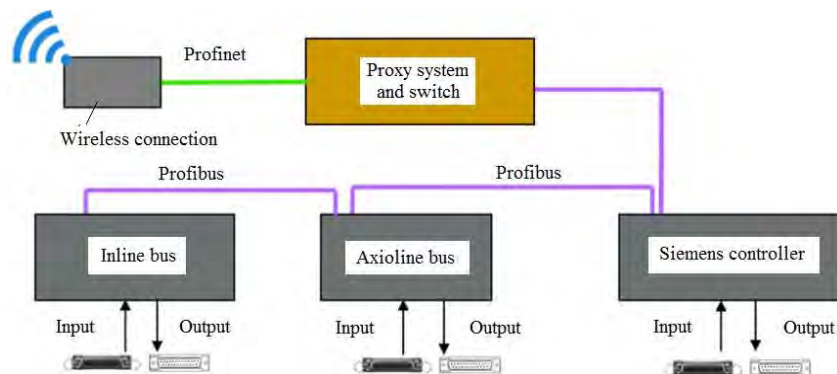


Fig. 2. Internal structure and external connections in TSL PROFIBUS hardware module



Profibus technology was created in 1989. At present time about 12.3 millions Profibus devices are installed (near 20% of the total quantity) in different automation systems [8]. Increasing of Profibus devices number is quite stable (for example, 0.8 million in 2018, but less than in 2017). In general it's possible to say that Profibus protocol/technology step by step will become relatively obsolete for strategic development and big projects, but will be used many years in future to realize compatibility between different generations of devices, appliances and equipment. That's why it's necessary to study this technology mainly for maintenance of installed devices and systems. But for future development it's recommended to shift attention to modern protocols/technologies where addressing is based on IP addresses and devices may

be reached using IP network directly without any additional proxy system like Profinet and EtherCAT which are also supported in TSL equipment.

In the same time about 26 millions Profinet devices are working in different industrial automation systems nowadays. More than 5.1 million devices were added in different projects in 2018 (12 % more than in 2017). Appearance and internal structure of Profinet hardware module presented in Figures 3, 4 accordingly.

Fig. 3. Appearance of TSL PROFINET hardware module

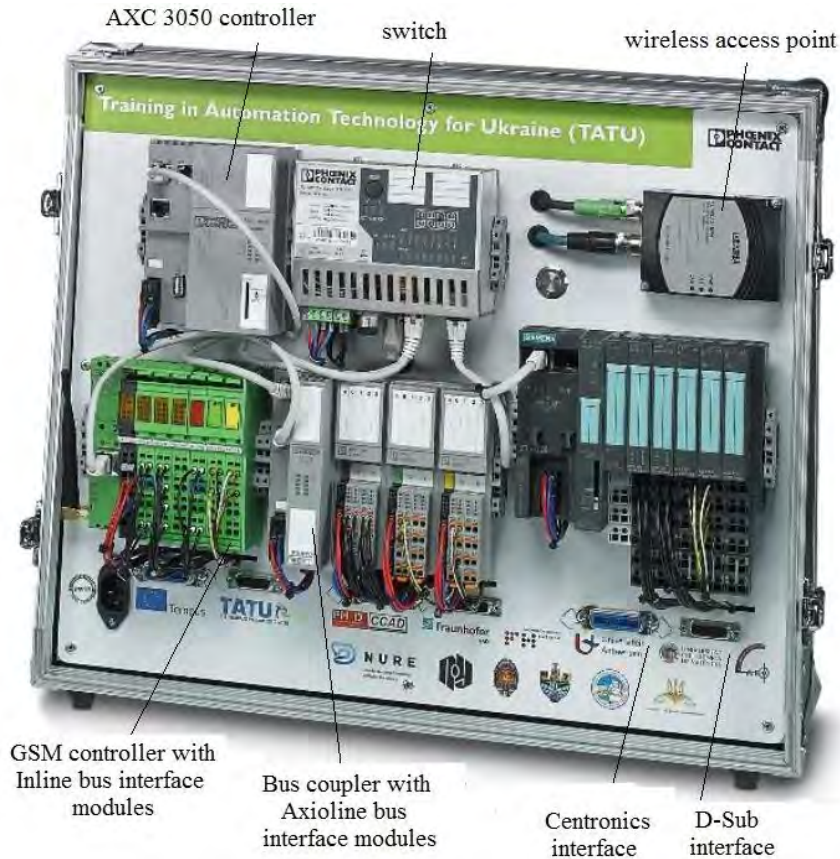
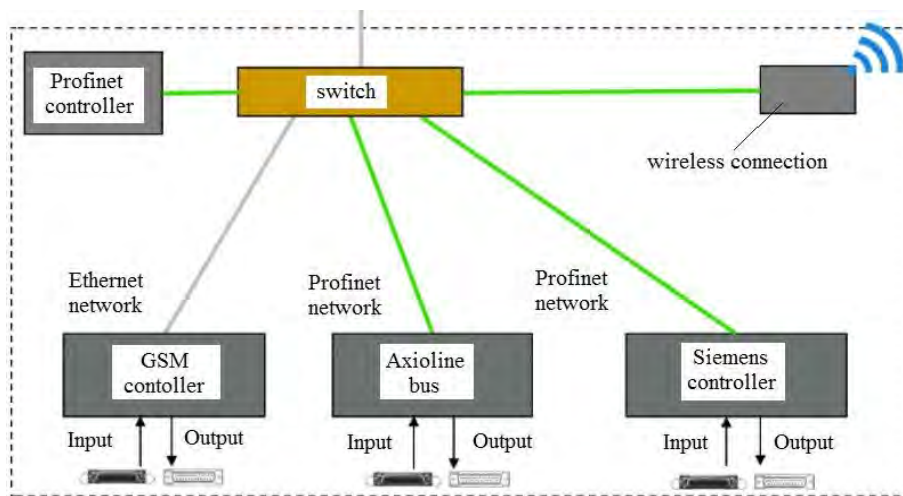
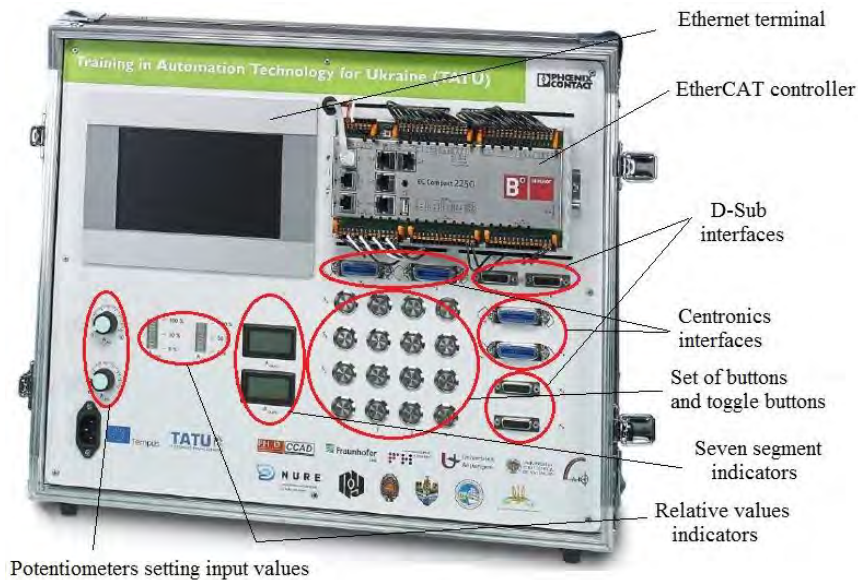


Fig. 4. Internal structure and external connections in TSL PROFINET hardware module



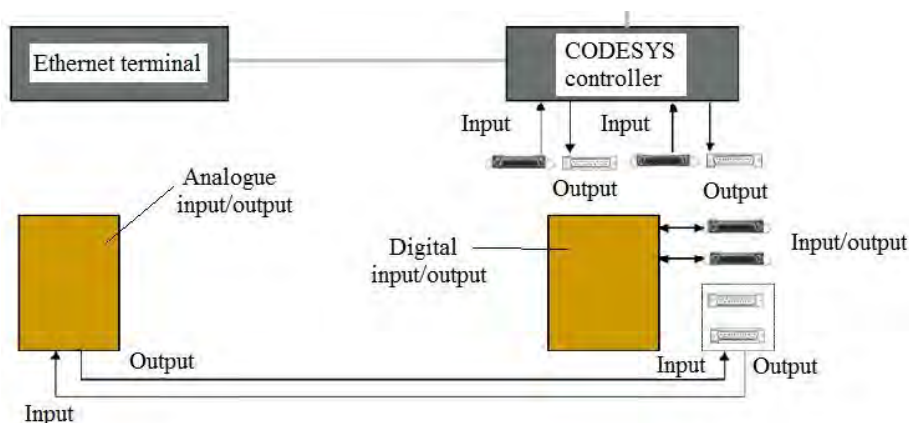
Appearance and internal structure of EtherCAT and Process Modeling HM presented in Figures 5, 6 accordingly. The third HM (Figure 5) is intended for modeling of technological processes. Models should be developed in CODESYS of 3.x versions (last accessible version is CODESYS V3.5 SP14 Patch 2) and loaded into the EtherCAT EC2250 controller. The graphical interface can be seen in the browser by entering the link <http://xxx.xxx.xxx.xxx:8080/webvisu.htm>, where xxx.xxx.xxx.xxx is the IP address of the EtherCAT EC2250 controller.

Fig. 5. Appearance of TSL EtherCAT and Process Modeling hardware module



For visualization it is possible to use the built-in graphic terminal Ethernet ET1007 WT. This module also allows to study the programming of controllers in CODESYS of 3.x versions. The third HM has various analog and digital inputs and outputs, as well as buttons that can be used for testing and simulating the operation of a highly complex control system. Each button has a built-in LED that is connected to the digital output. There are eight non locking and eight locking buttons as well.

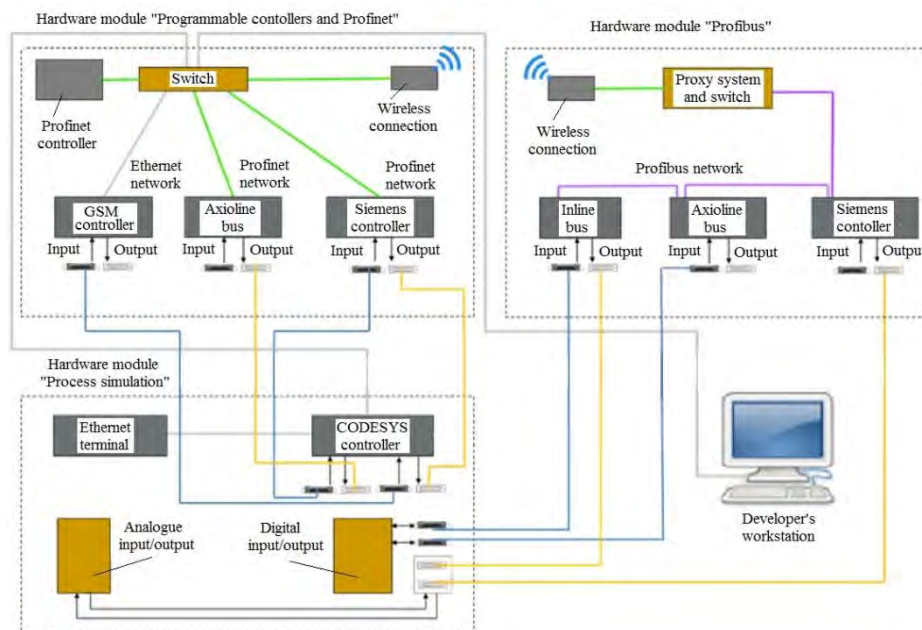
Fig. 6. Internal structure and external connections in TSL EtherCAT and Process Modeling HM



To provide physical connections between hardware modules, Centronics IEEE 488 connector with 24 pins and a 15-pin D-Sub connector are used. Up to 6 analog signals are connected to the D-Sub connector. The analog-to-digital conversion is performed at resolution capacity of 12 bits. The sample rate is 0.5 kHz. Only the third HM can be connected to other modules by standard cables, as their inputs and outputs are mounted symmetrically. All HMs may be connected to each other using standard cables as shown in Figure 7. These cables may also be used for connecting other external devices that do not have IP addresses. Devices that have IP addresses are connected to RJ-45 ports of Ethernet switches using a standard Cat. 5 twisted-pair cable. After the modules are switched, the control elements located in the EtherCAT and Process Modeling hardware module become available. Wireless possibilities of different types of modern equipment are very significant for a variety of tasks solution. That's why TATU TSL is equipped with two wireless access points (WAP), integrated in TSL Profibus HM and TSL Profinet HM. Structure of entire laboratory created for maritime engineers studying and retraining is shown in Fig. 8.

Modules and equipment which allow to explore different possibilities of modern cybersecurity hardware and protocols are absent in TATU equipment shipping. But as mentioned before, this field is very actual in modern conditions. Fortunately it's possible to add auxiliary modules or devices using standard DIN (Deutsches Institut für Normung; the German Institute for Standardization in English) rail and to connect them to base devices of TATU project or to another devices connected to the network by standard Ethernet technology.

Fig. 7. The structure of TSL hardware modules and their connection to computer



Majority of separate devices like PLCs, switches, bus couplers and so on, installed in TATU project, produced by Phoenix Contact company. That's why it was decided to explore devices with cyber security functions, created by exactly this company. Corresponding product line consist of following devices: FL mGuard RS2000, FL mGuard RS2005, TC mGuard RS2000, FL mGuard RS4000, FL mGuard RS4004, TC mGuard RS4000, FL mGuard GT/GT, TC mGuard PCI. In general these devices may work as LAN switches with different number of LAN ports, Internet routers, hardware firewalls (full stateful firewall), support cellular and Global Positioning System (GPS) capability, Virtual Private Network (VPN) hub capability, demilitarized zone (DMZ, protected network located between an untrusted and trusted

networks) capability, compatible with mGuard Secure Cloud (Industrial VPN for secure remote access) and may combine these functions and modes.

The following abbreviations are used in Figure 8: PLC – Programmable Logic Controller; BK – Bus Coupler (Bus Kupler in German language); SW – Switch.

Wired and wireless data exchange have certain strengths and weaknesses both. Wireless data exchange and corresponding devices allow to organize much more flexible remote control of complex industrial objects, unmanned or autonomous ships, aircrafts, cars, etc. Some of such projects are already realized at the present time and are planned for pretty close future. Such approach allows to solve such complex technical problems and tasks which were impossible to solve using wired data transfer systems.

There are two devices in mentioned product line which support wireless communications presented in Fig. .

1. Router TC MGUARD RS2000 3G VPN is security device with mobile phone interface. It is equipped with any SD memory card slot, supports two fixed VPN tunnels, has easy configurable firewall, router with NAT/1:1 NAT, four port Fast Ethernet switch, two slots for SIM cards and GPS receiver.
2. Router TC MGUARD RS4000 3G VPN is security device with mobile phone interface as well. It has NAT/1:1 NAT, 4-port managed switch. This is router with intelligent firewall with full scope of functions and VPN for 10 tunnels by default (up to 250 supported), CIFS integrity monitoring as an option, slot for SD memory card, slots for two SIM cards and GPS receiver.

Both devices use 50 Ω impedance SMA antenna socket. Supported satellite protocols are GPS and GLONASS.

Figure 8. Routers TC MGUARD RS2000 3G VPN and TC MGUARD RS4000 3G VPN



Wireless interfaces for both routers are described and presented in Table 1.

Table 1. Wireless interfaces for TC MGUARD RS2000 3G VPN and TC MGUARD RS4000 3G VPN routers

Supported wireless data transfer technologies	Frequencies, power, substandard	Data transfer rate	GPRS	EDGE	UMTS
GSM, GPRS, EDGE, UMTS, CDMA2000	850/900 MHz (2 W, EGSM); 1800/1900 MHz (1 W, EGSM); UMTS/HSPA B6; 850 MHz UMTS/HSPA B5; 900 MHz UMTS/HSPA B8; 1900 MHz UMTS/HSPA B2; 2100 MHz UMTS/HSPA B1; 800/1900 MHz CDMA2000 EVDO	14.4 Mbps and less (HSDPA) 5.7 Mbps and less (HSUPA) 3.1 Mbps and less (DL CDMA2000) 1.8 Mbps and less (UL CDMA2000)	Class 12, Class B CS1...CS4	Multislot Class 12	HSPA 3GPP R6

The following abbreviations are used in the Table 1: GSM – Global System for Mobile communications, GPRS – General Packet Radio Service, EDGE – Enhanced Data rates for GSM Evolution, EVDO – EVolution-Data Optimized, GPS – Global Positioning System; GLONASS – GLOBAL NAVIGATION Satellite System; EGSM – Extended Global System for Mobile communications), UMTS – Universal Mobile Telecommunications System, HSPA – High Speed Packet Access, CDMA – Code Division Multiple Access, HSDPA – High Speed Downlink Packet Access, HSUPA – High-Speed Uplink Packet Access, DL – DownLink, UL – UpLink, 3GPP – 3rd Generation Partnership Project, CS – Coding Schemes.

Both devices support the same network functions: 4 time slots for receiving data, 4 time slots for transmitting data. The PIN is saved in the modem. After a voltage interruption, there is automatic redialing into the network. Integrated TCP/IP stack, firewall and VPN support, independent connection establishment. Web-based management by SNMP is supported as well.

Table 2. Wired interfaces for TC MGUARD RS2000 3G VPN and TC MGUARD RS4000 3G VPN routers

	Interface type	Number and type of ports	Cable segment length, m	Supported protocols or data flow control	File format and coding	Data transfer rate, kbps
TC MGUARD RS2000 3G VPN	Ethernet, 10/100Base-T(X) IEEE 802.3u	4 RJ45	100 (STP)	TCP/IP, UDP/IP, FTP, HTTP; ARP, DHCP, PING (ICMP), SNMP, SMTP		
	V.24 (RS-232) interface in acc. with ITU-T V.28, EIA/TIA-232, DIN 66259-1	1 D-SUB 9 plug	15	Software handshake, Xon/Xoff or hardware handshake RTS/CTS	UART/NRZ : 8 Data, 1/2 Stop, None/Even/Odd Parity	9.6; 19.2; 38.4; 57.6; 115.2
TC MGUARD RS4000 3G VPN	Ethernet, 10/100Base-T(X) in acc. with IEEE 802.3u	6 RJ45	100 (STP)	TCP/IP, UDP/IP, FTP, HTTP; ARP, DHCP, PING (ICMP), SNMP, SMTP		
	V.24 (RS-232) interface in acc. with ITU-T V.28, EIA/TIA-232, DIN 66259-1	1 D-SUB 9 plug	15	Software handshake, Xon/Xoff or hardware handshake RTS/CTS	UART/NRZ : 8 Data, 1/2 Stop, None/Even/Odd Parity	9.6; 19.2; 38.4; 57.6; 115.2

The following abbreviations are used in the Table 2: STP – shielded twisted pair; ITU-T – International Telecommunication Union Telecommunication Standardization Sector; IEEE – Institute of Electrical and Electronics Engineers; RTS – Request To Send; CTS – Clear To Send; UART – Universal Asynchronous Receiver-Transmitter; NRZ – Non Return to Zero; RS – Recommended Standard; DHCP – Dynamic Host Configuration Protocol; HTTP – Hyper Text Transfer Protocol; SNMP – Simple Network Management Protocol; NAT – Network Address Translation; FTP – File Transfer Protocol; IP – Internet Protocol; TCP – Transmission Control Protocol; UDP – User Datagram Protocol; ARP – Address Resolution Protocol; ICMP – Internet Control Message Protocol; EIA/TIA – Electronic Industries Alliance/Telecommunication Industries Association.

It is meaningful and recommended to connect devices of mGuard product line to AXC 3050 controller because it is most productive PLC among another devices implemented in TATU project. By another words, it is the best way to connect any mGuard device to TSL PROFINET hardware module. PLC AXC 3050 can work with Ethernet family networks and the Axioline F local bus, which supports any Ethernet-based data transfer protocols. The Axioline station can be created by connecting Axioline modules to the controller. The Axioline F local bus can be used for the sequential installation of various modules (devices) one closely to the other. The AXC 3050 controller can be fully configured and programmed in one of five programming languages in accordance with IEC 61131-3 standard with PC Worx when connected over Ethernet network. It has built-in interfaces for connecting devices over Ethernet

network. It allows to configure the controller using TCP/IP or UDP (User Datagram Protocol) protocols. The controller has three integrated Ethernet ports X1, X2, X3.

Using function blocks IP_USEND (sending user data via TCP/IP protocol) and IP_URCV (receiving user data via TCP/IP protocol) in PC Worx, it's possible to organize data exchange (i.e., values of variables corresponding to the measured process parameters and physical quantities) between the PLCs. This approach allows implementing distributed and configurable automation solutions. By using the AX OPC server (Object Linking and Embedding for Process Control, a collection of software technologies that provide a single interface for managing automation objects and technological processes), the controller is accessible over Ethernet network and can be used in software visualization packages.

The PROFINET technology can be implemented by connecting to the Ethernet interfaces of the AXC 3050 PLC. The PROFINET controller is always available when connected via the eight-pin RJ45 connector of the X3 interface. Modbus TCP technology can also be implemented by connecting to the Ethernet interfaces of the AXC 3050 controller. This controller can act as a Modbus client, and can be configured as a MODBUS TCP server when using its corresponding function blocks.

AXC 3050 PLC has communication interface with the local Axioline F bus for connecting various modules. Up to 63 devices can be connected to this PLC. The actual number of devices depends on the total current consumption of all devices, which should not exceed the maximum current that the controller provides to the local bus. Due to the Web-based management interface integrated into the PLC, the user can visualize the status and diagnostic information from the controller in the browser. The AXC 3050 PLC is equipped with two USB interfaces and has internal memory. It can be used for storing programs and configurations for a custom project. If the internal memory is insufficient for the created application, the AXC 3050 can work with external memory in the form of SD format flash memory (Secure Digital) or USB drive. Also AXC 3050 has 4 MB internal memory for program storage, and 8 MB memory for data storage; 128 kB is used for storing data after power off. The minimum controller cycle time is 1 ms, the number of control tasks performed simultaneously is 16. It is also possible to create complex multi segment industrial networks using this PLC model [9].

It is obviously that protocols and technologies of cybersecurity mentioned and briefly described above can not be learned in brief term especially together with wide spectrum of wired and wireless industrial data transfer protocols and technologies. That's why it is proposed to use multi level approach which consist of the following stages as partly mentioned above.

1. Basics of PLCs programming using PcWorx and CODESYS IDEs and corresponding IDEs of another developers if necessary (like very popular Siemens Simatic Step 7, Mitsubishi GX Developer, Schneider Unity Pro and so on).
2. Studying classic industrial technologies/protocols like ProfiBus, ModBus, ASI, HART, etc.
3. Studying of modern perspective industrial technologies/protocols like Profinet, ModBus TCP, HART IP, EtherCAT, etc.
4. Studying of wireless data transfer technologies based on IEEE 802.11 family, GSM standards, Bluetooth, Zigbee and so on.
5. Cybersecurity protocols and technologies.

4. ACTUAL OR ANTICIPATED OUTCOMES

Equipment obtained at European Tempus TATU project performing allows to learn PcWorx and CODESYS integrated development environments for programmable logic controllers programming and to study the following network devices: switches, wireless access points, different types of programmable logic controllers and some another equipment as well. Full time actively working laboratory "Means of industrial automation and network technologies" is created. In general it allows to learn studying disciplines, connected with mentioned above areas. E-learning system based on MOODLE platform is actively used for students' remote access to corresponding teaching materials and is constantly updated. Learning books in Russian, Ukrainian and English languages are created and successfully integrated in the education process. At least 200 students of "Ships' power plants operation", "Ships' power and refrigerating plants operation", "Automated Control of Ships' Power Plants", "Operation and Maintenance of Ship's Automated Systems" specialties pass corresponding lessons every year. Also there are a lot of potential consumers of such education and trainings because there are 187 crewing and shipping companies in Odessa region. Ukraine has 69000 seafarers (39000 officers) and keeps 6th place in the world on this indicator as well.

Author has some experience with industrial cyber security devices adjustment and different manufacturers devices integration in the same network. Bundled with PLCs, network switches, wireless access points it allows to learn studying disciplines, connected with most mentioned above areas.

5. CONCLUSIONS

Ways of modern concepts and technologies implementing in maritime field are analyzed. Concrete directions of deep studying are shown. Possibilities and technologies, successfully realized in education process, are described. Possibilities of existing equipment may be expanded by additional modules installation. Actuality and possibilities of cyber security technologies studying are highlighted. Approaches and technologies, successfully realized in education process and planned for future, are described.

REFERENCES

- [1] LANGMANN R. "Workshop: The TATU Lab & smart education" [Text] /R. Langmann, Y.Makarova, L. Rojas-Peña, P. Galkin, I. Klyuchnik, V. Voropaeva, V. Pozepaev, L. Zinyuk, R. Skrypyuk, E. Shaporina, V. Shaporin, V. Shapo, S. Gorb// 2016 13th International Conference on Remote Engineering and Virtual Instrumentation (REV).– Madrid, 2016.–P. 400-402.
- [2] GORB S. I., NIKOLSKII V. V., SHAPO V. F., KHNIUNIN S. G. Programmirivanie controllerov v instrumentalnoi srede: uchebnoe posobie. – Kharkov: Izdatel' FLP Panov A.N., 2017. – 172 s. In Russian.
- Горб С. И., Никольский В. В., Шапо В. Ф., Хнюнин С. Г. Программирование контроллеров в инструментальной среде: учебное пособие. – Харьков: Издатель ФЛП Панов А.Н., 2017. – 172 с.
- [3] GORB S.I., NIKOLSKYI V.V., SHAPO V.F., KHNIUNIN S.H. Programming controllers in the integrated development environment: training manual. Practice. – Odessa: National University "Odessa Maritime Academy", 2017. – 164 p.
- [4] TATU study book. Trainings in Automation Technology for Ukraine. Editors: C. Madritsch, W.Werth. – Villach: Carinthia University of Applied Sciences, 2017. – 211 p.
- [5] GORB S. I., NIKOLSKII V. V., KHNIUNIN S. G., SHAPO V. F. Tekhnicheskoe obespechenie podgotovki sudovykh ingenerov po sistemam avtomatizatsii s programmiruemymi controllerami. // Avtomatizatsiia sudovykh tekhnicheskikh sredstv: nauch.-tekhn. sb. – 2016. – Vyp. 22. – Odessa: ONMA. – S. 39 – 46. In Russian.
- Горб С.И., Никольский В.В., Хнюнин С.Г., Шапо В.Ф. Техническое обеспечение подготовки судовых инженеров по системам автоматизации с программируемыми контроллерами // Автоматизация судовых технических средств: науч.-техн. сб. – 2016. – Вып. 22. – Одесса: ОНМА. – С. 39 – 46.
- [6] GORB S. I., NIKOLSKII V. V., KHNIUNIN S. G., SHAPO V. F. Metodicheskoe obespechenie tekhnologii avtomatizatsii na baze programmiruemyykh controllerov // Avtomatizatsiia sudovykh tekhnicheskikh sredstv: nauch.-tekhn. sb. – 2017. – Vyp. 23. – Odessa: NU "OMA". – S. 30 – 36. In Russian.
- Горб С.И., Никольский В.В., Хнюнин С.Г., Шапо В.Ф. Методическое обеспечение технологий автоматизации на базе программируемых контроллеров // Автоматизация судовых технических средств: науч.-техн. сб. – 2017. – Вып. 23. – Одесса: НУ "ОМА". – С. 30 – 36.
- [7] IVASIUK N., SHAPO V. Unified English Language Communication as Service for Seafarers // 30th International Maritime English Conference IMEC 30. – Maritime Academy of Asia and the Pacific. – Manila, 2018.
- [8] PROFIBUS and PROFINET International. PROFIsafe and IO-Link pass the 10 million mark. – <https://www.Profibus.com/newsroom/news/profifSAFE-and-io-link-pass-the-10-million-mark/>
- [9] SHAPO V. Programmable Logic Controllers Applying for Multi Segment Industrial Data Transfer Networks Developing. International Robotics & Automation Journal. – Volume 3, Issue 4. – 2017. [Electronic resource]: <http://medcraveonline.com/IRATJ/IRATJ-03-00060.php>

A CRITICAL APPROACH TO THE PARTICLE SWARM OPTIMIZATION METHOD FOR FINDING MAXIMUM POINTS

Mine SERTSÖZ & Mehmet FİDAN***

** Assist. Prof. Dr., Eskisehir Technical University,
TURKEY, e-mail: msertsoz@eskisehir.edu.tr
ORCID: <https://orcid.org/0000-0003-1641-9191>*

*** Assoc. Prof. Dr., Eskisehir Technical University,
TURKEY, e-mail: mfidan@eskisehir.edu.tr
ORCID: <https://orcid.org/0000-0003-2883-9863>*

Received: 8 January 2020, Accepted: 22 April 2020

ABSTRACT

Particle Swarm is an optimization method that is used for solving industrial problems and is highly preferred due to its ease of use and it's ability to find accurate results rapidly in recent years. In this study, it was used to optimize the resistance value of train sets.

There are many types of resistance in train sets and the train can't start moving until the traction motors overcome the resistances. Run resistance, ramp resistance, and curve resistance are the resistances that the train must overcome at a constant speed. However, it is known that the acceleration of high-speed trains is very high and the resistance that the train sets must overcome for the change in speeds is acceleration resistance.

This study aimed to calculate the acceleration, time, curve, ramp and distance, under certain constraints, for the total resistance value of YHT 65000 train by using the Particle Swarm Method as to obtain the minimum and maximum. Although, the results showed that the Particle Swarm Method returned very successful results for the minimum resistance, the same cannot be said for the maximum resistance.

Key Words: *Railway Systems, Energy Efficiency, Optimization, Particle Swarm Method.*

1. INTRODUCTION

Efficient use of energy is an important research topic in recent years. Efficient use of depleted resources, in spite of the increasing world population, is a precaution against a lack of energy in the future. Considering the sectoral productivity in Turkey, it was determined that there exists the potential for significant energy savings. The distribution is as follows: 30% in the building sector, 20% in the industrial sector, 15% in the transportation sector [1]. This study is an optimization problem for the energy efficiency of rail systems, which is an important part of the transportation sector.

Optimization of the rail system has many subheadings. These are the design of the train, the use of auxiliary equipment, (such as ventilation, the door opening and closing system), efficient driving, regenerative braking energy, route planning, energy storage, signaling, the construction phase etc. In fact, the aim of optimization in rail transport is to reduce energy consumption without compromising quality and reliability as in all optimization problems. In this section, some of the main studies in this field are given.

According to the efficient driving theory, it is seen that electricity savings will be between 15-35% [2], [3], [4], [5], [6], [7], [8], [9]. Another case study was carried out and a slight improvement in travel time was envisaged but energy savings rose by up to 6% in any subway [10]. It is important to know the energy consumption along curves, slopes, and at different speed, etc. for efficient driving. Optimization looks to achieve the best combination of all these parameters.

When it comes to the resistance of the train sets, and to examine the subject in more detail, the optimization process can be traced back to the oldest periods of development in the railways. Many researchers have made investigations in this field and have reached the empirical equations shared in the findings section. Studies in literature are mainly based on cruise resistance and their prediction models. Travel resistance was reported by Davis [11] in 1926 as follows:

$$R_s = AV^2 + BV + C$$

A is a constant which changes proportionally to the square of the speed and represents aerodynamic resistance caused by air pressure and friction.

B, is a constant which is responsible for mechanical resistances and HVAC (Heating, Ventilating and Air Conditioning).

C, is a constant which is not fixed to the vehicle speed, but is a function of weight.

In the past, detailed tests have been conducted to determine these constants. The cruise resistance coefficients of different trains were found for the Shinkansen. [12] In addition, different tests and cruise resistance tests were applied to the passenger cars and locomotives of Eurofim [13]. However, since the tests are very costly, different empirical equations have been developed in the past for estimating the resistance of certain trains. An overview of the methods adopted by the main national railways (up to 2000) and a calculation tool, to calculate cruise resistance, in which the effects of various characteristics of the train's architecture can be taken into account, are presented; these results are compared with the results of other equations for calculating train resistance [14].

More recently, Lukaszewicz has proposed a method that allows the determination of train resistance coefficients by measuring only train speed and position from full-scale cruise tests [15]. In this study, resistance was determined by the change in kinetic and potential energy of a train traveling between successful measurement points. Using this method [16], the same authors shared experimental results to determine the travel resistance of different trains and the

effect of variables such as speed, number of axles, number of wagons, axle load, road type and train length. Since 2005, a CEN (European Committee for Standardization) standard [17] has described methodologies for evaluating the coefficients of Davis's formula starting from a predictive formula, numerical simulations and reduced-scale tests from full-scale test measurements, but no strictly accepted methods have been obtained.

Cruise tests are performed to determine the speed dependent terms (A and B) according to CEN Standards. There is a need for a special test for term C, which means that the train is traveling at a very low speed. In order to find the coefficients A and B in the CEN standard, the regression method and the velocity history identification method were used. The first cruise test is based on the combination of all available experimental data and the second is based on the combination of the equation of motion. Both methods require a very good knowledge of the test section properties (slopes and curve radiuses).

In another study in the literature, the standard methods for determining Davis' coefficients were compared to new methods. In particular, it has been shown that the three coefficients of the Davis' formula can be estimated by two tests only, the first is a very low speed test on a high altitude slope section (without having to perform a traction test), and the second is a travel test starting at the train's maximum speed. It also proposed a regression method, which is a new method to define the A and B coefficients in the Davis equation. The main advantage of this method is that it does not need to know the characteristics and coefficient C of the railway line. Starting from experimental full-scale tests (characterized by a mass of 450 tonnes) scaled for a general ideal train; the entire procedure for determining travel resistance coefficients is described. The comparison of the results obtained by different methods for estimating the coefficients A and B of the Davis equation is presented and analyzed [18].

In this study, different from the above-mentioned studies, a single mathematical model was used to determine total resistance by using empirical equations which were accepted for all resistances. Then, it was determined how much acceleration, time, curve, ramp and distance are required for the minimum and maximum conditions of this model. For this purpose, the Particle Swarm Optimization (PSO) method is used.

2. METHOD

The method to find the optimum working point is the PSO method because, in both linear and non-linear problems, finding the roots of equations and solving industrial problems, (as in this study), are just some of the areas in which it is used. From a performance standpoint, both for speed and simplicity, it has advantages over other optimization techniques. PSO is one of the types of algorithms that respond well to intuitive and stochastic processes. It was named because it was inspired by the adaptation of living beings to their living conditions and by acting on intuition.

Details of this method are given below.

2.1 PSO Method

There are many algorithms which have been produced that reflect the behavior of living beings in nature. These include the Ant System [19], the Max-Min Ant System [20], Particle Swarm Optimization [21], Artificial Bee Colony [22], the Fruit Fly Optimization Algorithm [23], Cuckoo optimization based on Levy Flight [24], the Krill Herd Optimization Algorithm [25], Bakeri Foraging Behavior [26], the Bat Algorithm [27], the Firefly Algorithm [28], the Lion Algorithm [29], the Gray Wolf Algorithm [30], the Dolphin Algorithm [31], the Bush Colony Algorithm [32], the Artificial Algae Algorithm [33], the Virus Colony Search Algorithm [34], the Shark Olfaction Optimization Algorithm [35] and the Social Spider Algorithm [36].

Among all these algorithms, particle swarm optimization is the most cited intuitive intelligence algorithm with the cited number is 5721 [37]. This method was developed by a social psychologist and an electrical engineer about thirty years ago [21]. In fact, it is an algorithm developed entirely by studying the random behavior of fish and birds in order to survive. PSO is based on social information sharing among individuals in the swarm. The search is performed by the generation number as in the genetic algorithm. Here, in fact, individuals are called particles, and the community of these particles is called the swarm. This optimization, based on the experience of the previous position of the particle, each individual tries to approach the individual which is in the best position in the swarm. The speed of this approach is random and the assumption is that the next step is better than the previous one. This approach continues until it reaches the goal (i.e. the best position). Although it is similar to the genetic algorithm (GA) method, it is easier to use than GA and responds better in some studies.

In a PSO, a sequence of particles with random positions and velocities is initiated at size D. Dimension D is also equal to the unknown number in the conformity function. The goal here is to find the best value by updating its generations. At each iteration, each particle is updated according to the two “best” values. In fact there are two aspects to the best value. The first is the best suitability value a particle has ever found. This value is stored in memory for use later and is referred to as “pbest”, the best value of the particle. The second best value is the best fitness value that any particle in the swarm has ever achieved. This value is the global best value for the swarm and is called “gbest”. The speeds and positions are changed according to these new assigned values. The swarm particle matrix is nxD in size. where n is the number of particles.

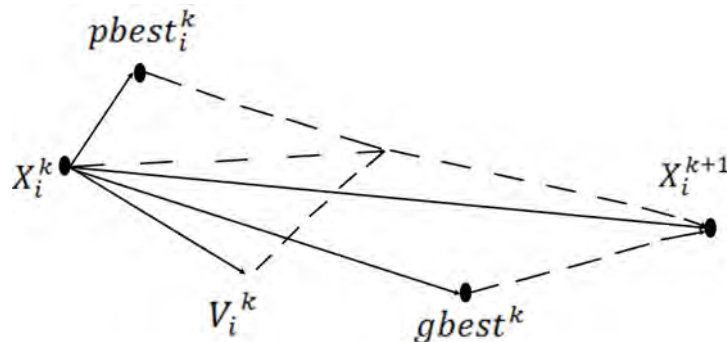
$$X = \begin{bmatrix} X_{11} & \cdots & X_{1D} \\ \vdots & \ddots & \vdots \\ X_{n1} & \cdots & X_{nD} \end{bmatrix} \quad (1)$$

Particle updates velocity (amount of change of position in each size) and position according to the following statements:

$$V_i^{k+1} = V_i^k + c1 * rand_1^k(pbest_i^k - x_i^k) + c2 * rand_2^k(gbest^k - x_i^k) \quad (2)$$

$$X_i^{k+1} = X_i^k + V_i^{k+1} \quad (3)$$

Figure 1. Working Principle of Particle Swarm Optimization (Eberhart, 1995)



Particle number: There are 20 to 40. For many problems it is enough to use 10 particles, while for some difficult or special problems it may be necessary to use 100 or 200 particles.

Particle dimension: It depends on the problem to be optimized.

Particle spacing: Particles of different sizes and ranges can be identified, depending on the problem to be optimized.

Vmax: In an iteration, it determines the maximum change (velocity) in a particle. It is usually determined by particle spacing.

Learning Factors: c_1 and c_2 are generally selected as 2. But different values can also be selected.

Stop Condition: The algorithm can be stopped when the maximum number of iterations is reached or the value function reaches the desired level. For multiple model problems, the PSO algorithm often fails to achieve satisfactory results due to early convergence [38], [39]. The solutions obtained using the standard PSO algorithm are also unsatisfactory for some single model problems. Since PSO is not guaranteed to approach the local optimum [40], solutions are often developed using finely tuned local search methods [41], [42], [43]. Therefore, neither the search nor the search mechanism in the standard PSO algorithm is sufficient for different types of problems. In order to improve research efficiency and address the shortcomings in the standard algorithm, researchers have proposed some changes to the PSO method [44].

3. YHT 65000 FAST TRAIN

This train is a high-speed train model that is currently used in Turkey. It is a high speed train set produced by the Spanish railway manufacturer Construcciones y Auxiliar de Ferrocarriles (CAF).

YHT 65000 trains are based on the trains that RENFE (Red Nacional De Ferrocarriles Espanoles) Class with 120 trains use in Spain. A set consists of 6 cars as standard. In this study, it was thought that there were 6 cars. However, it has a modular structure and 2 more cars can be added if desired. In addition, 2 sets can be combined to form a total of 12 cars. Before this study, the technical information of the high-speed train used in the study is given in Table 1.

Table 1. Technical Information of High Speed YHT 65000 Train *

Main Characteristics	YHT 65000
Power	38400 kW
Lokomotive Load	297,25 Ton
Axle Load	17 Ton
Axle Type	-
Maximum Velocity	275 km/h
Line Gap	1435 mm
Catenary Type	AC 25 kV, 50 Hz
Traction Motor Power	AC 4800 kW

*Obtained from TCDD (Turkish State Railways).

Figure 2. YHT 65000 High Speed Train (<https://sites.google.com>)



4. RESULTS

In this study, four resistances which prevent the movement of high speed trains were calculated. These were cruise resistance (car resistance and locomotive resistance, not as a separate resistance in high-speed train sets (one resistance)), curve resistance, ramp resistance and acceleration resistance. Since wind resistance is a chaotic resistance, it was not taken into account. It should be noted that these resistors directly affect power consumption. In this case, it is possible to express the total resistance (RT) equation as follows (G is the total load carried in tonnes):

Cruise Resistance:

$$R_s = (1,3953 - 0,0071 * V + 0,0006 * V^2)G \quad (1)$$

Since cruise resistance exists for a high-speed train set, it consists of a single resistance provided by the manufacturer, which is inseparable as car and locomotive resistance.

Curve Resistance:

$$R_k = \left(\frac{650}{k-55}\right)G \quad (2)$$

This curve resistance formula is known as the Röcki formula and is used for 1435 mm line length. The k value in the equation is the curvature radius of the line in m.

Ramp Resistance:

$$R_r = rG \quad (3)$$

r is the ramp value in ‰. This value is taken as positive when climbing the ramp and negative when descending.

In order for the train set to move, it must overcome these resistances. A train can only move with "Steady" velocity after overcoming these resistances. At steady velocity, there is no

acceleration (a) (it is equal to zero) according to Newton's 1st Law. There is one more resistance must be overcome when the train wants to change its velocity. This resistance is called as acceleration resistance.

Acceleration Resistance:

$$R_a = \left(\frac{4V^2}{S}\right)G \tag{4}$$

The acceleration resistance given above is the acceleration resistance of the train set. S refers to the line.

While there is no acceleration in the first three resistance types, but in the fourth one, there is a rise in acceleration resistance when the speed changes. The power consumption is determined by applying the PSO method to the total resistance formula given below.

$$R = R_s + R_k + R_r + R_a \tag{5}$$

The equation in full is written as:

$$R = \left(V^2 \left(0.0006 + \frac{4}{S}\right) - 0.0071V + 1.3953 + \frac{650}{K-55} + r\right)G \tag{6}$$

$$V = at \tag{7}$$

In this study, resistance was minimized and maximized in 20 iterations with the Particle Swarm Optimization Method. Constraints and results (Table 2.) are given below.

Constraints:

$-28\text{m/s}^2 < a < 28\text{ m/s}^2$ (acceleration)

$1\text{ s.} < t < 3600\text{ s.}$ (time)

$-\%26 < r < \%26$ (ramp)

$130\text{ m.} < k < 530\text{ m.}$ (curve)

$0\text{ m.} < S < 300\text{ km.}$ (distance)

Table 2. Values Found Using the Swarm Particle Method

	a	t	r	k	S
Situations for the Least Resistance	10 m/s ²	0 s.	-%26	530 m.	300 km.
Situations for the Highest Resistance	-18.2 m/s ²	3163 s.	-%19.2	206 m.	10 m.

Table 2 shows that the total resistance is the smallest gave quite reasonable results. Resistance values are the smallest values except for acceleration resistance. However, in cases where resistance is the highest different results have been obtained instead of expected upper limits.

5. CONCLUSION

By means of the PSO method used, the points where the least power was consumed, so the minimum resistance, were found in the extreme constraints given, with the exception of acceleration. However, the acceleration, time, curve, ramp and distance values make the highest resistance not be obtained correctly with the PSO method. This is due to the fact that the number of iterations, 20, was not sufficient to find the parameters that make the lowest resistance value, but not enough to find the highest resistance.

Two solutions can be proposed here. The first one is that the number of iterations can be increased and more accurate results can be obtained. when the number of iterations is 1000, the results are more accurate, but this greatly extends the test runtime and it becomes impractical. While 20 iterations were 1.88 s, it was 795 s for 1000 iterations. So the time increased almost 422.87 times.

A second way is to keep the number of iterations of the particle swarm optimization method at 20 again while finding the maximum resistance, but by hybridizing the optimization method with a different method to eliminate the disadvantages of the rapid convergence of PSO. Thus, the right result can be achieved and save time. The authors plan to create such a method as a second step.

REFERENCES

- [1] DOĞAN, H., YILANKIRKAN, N., “Türkiye’nin Enerji Verimliliği Potansiyeli ve Projeksiyonu”, Gazi Üniversitesi Fen Bilimleri Dergisi Part:C, Tasarım Ve Teknoloji GU J Sci Part:C 3(1):375-383 (2015).
- [2] RSSB. T618 technical report: improving the efficiency of traction energy use. London: RSSB; 2007.
- [3] ANDERSON, R., MAXWELL, R., HARRIS, N. “Maximizing the potential for metros to reduce energy consumption and deliver low-carbon transportation in cities”, Working paper for the CoMET and Nova Metro Benchmarking Groups; 2009.
- [4] KOKKEN, K. “The reduction of energy consumption in EMU trains”, 6th World congress on railway research (WCRR), Edinburgh; 2003.
- [5] BOCHARNIKOV, Y., TOBIAS, A., ROBERTS, C., HILLMANSEN, S., GOODMAN, C. “Optimal driving strategies for traction energy saving on DC suburban railways”, IEEE Electr Power Appl 2007;1:675–82.
- [6] CORAPI, G., DE MARTINIS, V., PLACIDO, A., DE LUCA, G. “Impacts of energy saving strategies (ESSs) on rail services and related effects on travel demand”, WIT transactions on the built environment, Rome; 2014.
- [7] HULL, G., ROBERTS, C., HILLMANSEN, S. “Simulation of energy efficiency improvement on commuter railways”, IET conference on railway traction systems, Birmingham; 2010.
- [8] HU, W., SUN, Q., LV, J. “Research on subway trains’ energy conservation running based on PSO”, International conference on information science, electronics and electrical engineering (ISEEE), Sapporo; 2014.
- [9] RODRIGO, E., TAPIA, S., MERA, JM., SOLER, M. “Optimizing electric rail energy consumption using the lagrange multiplier technique”, J Transp Eng 2013;139(3):321–9.
- [10] XIN, T., ROBERTS, C., HE, J., HILLMANSEN, S., ZHAO, N., CHEN, L., ve diğerleri “Railway vertical alignment optimisation at stations to minimise energy”, IEEE 17th international conference on intelligent transportation systems, Qingdao; 2014.
- [11] DAVIS Jr., W.J., “The tractive resistance of electric locomotives and cars”, Gen. Electr. Rev, 29, 2-24, 1926.
- [12] HARA, T., OHKUSHI, J., NISHIMURA, B., “Aerodynamic drag of trains”, Q. Rep. RTRI, 8 (4), 226-229, 1967.
- [13] Report ERRI C, 179/RP 9, Utrecht, April, 1993.
- [14] ROCHARD, B.P., SCHMID, F., “A review of methods to measure and calculate train resistances”, Proceedings of the Institution of Mechanical Engineers, Part F: Journal of Rail and Rapid Transit, 214(4), 185-199, 2000.
- [15] LUKASZEWICZ, P., “A simple method to determine train running resistance from full-scale measurements”, Proceedings of the Institution of Mechanical Engineers, Part F: Journal of Rail and Rapid Transit, 221(3), 331-337, 2007.
- [16] LUKASZEWICZ P., “Running resistance - Results and analysis of full-scale tests with passenger and freight trains in Sweden”, Proceedings of the Institution of Mechanical Engineers, Part F: Journal of Rail and Rapid Transit, 221 (2), 183-193, 2007.

- [17] EN 14067-4 (2005) - A1 (2009). Railway applications - Aerodynamics – Part 4: Requirements and test procedures for aerodynamics on open track.
- [18] SOMASCHINI, C., ROCCHI, D., TOMASINI G. and SCHITO P. “Simplified Estimation of Train Resistance Parameters: Full Scale Experimental Tests and Analysis”, Proceedings of the Third International Conference on Railway Technology: Research, Development and Maintenance 2016; Paper 58.
- [19] DORIGO, M., MANIEZZO, V., COLORNI A., “The Ant System: Optimization by a colony of cooperating agents”, IEEE Transactions on Systems, Man, and Cybernetics– Part B, Vol.26, No.1, 1996, pp.1-13. DOI: 10.1109/3477.484436.
- [20] STUTZLE, T. ve HOOS, HH, “The Max-Min ANT System and Local Search for Combinatorial Optimization Problems”, June 2000 Future Generation Computer Systems 16. DOI: 10.1007/978-1-4615-5775-3_22.
- [21] EBERHART, R. C. and KENNEDY, J., “A new optimizer using particle swarm theory”, Proceedings of the Sixth International Symposium on Micro Machine and Human Science, Nagoya, Japan, 39-43. Piscataway, NJ: IEEE Service Center, 1995.
- [22] KARABOGA, D., BASTURK, B., “Sayısal fonksiyon optimizasyonu için güçlü ve verimli bir algoritma: Yapay arı kolonisi (ABC) algoritması”, Journal Of Global Optimazition 39(3) (2007).
- [23] PAN, W., “A new Fruit Fly Optimization Algorithm”, Taking the financial distress model as an example”, Knowledge-Based Systems, Volume 26, February 2012, Pages 69-74. DOI: 10.1016/j.knosys.2011.07.001
- [24] YANG, X.S. DEB, S., “Cuckoo Search via Lévy flights”, 2009 World Congress on Nature & Biologically Inspired Computing (NaBIC), 9-11 Dec. 2009, DOI:10.1109/NABIC.2009.5393690.
- [25] GANDOMI, A.H., ALAVI A.H., “Krill Herd: A new bio-inspired optimization algorithm”, Communications in Nonlinear Science and Numerical Simulation Volume 17, Issue 12, December 2012, Pages 4831-4845. DOI: 10.1016/j.cnsns.2012.05.010.
- [26] PASSINO, K.M., “Biomimicry of bacterial foraging for distributed optimization and control”, IEEE Control Systems Magazine, Volume: 22 , Page(s): 52 - 67 Issue: 3 , June 2002. DOI: 10.1109/MCS.2002.1004010.
- [27] YANG, X.S., “A New Metaheuristic Bat-Inspired Algorithm”, International Workshop on Nature Inspired Cooperative Strategies for Optimization (NICSO 2008), Tenerife Spain, (2008).
- [28] YANG X.S., “Lecture Notes in Computer Science ”, 5792 (2009) 169-178.
- [29] RAJAKUMAR B.R., Procedia Technology 6 (2012) 126-135.
- [30] MIRJALILI, S., MIRJALILI, S.M., LEWIS A., “Grey Wolf Optimizer”, Advances in Engineering Software Volume 69, March 2014, Pages 46-61. DOI: 10.1016/j.advengsoft.2013.12.007.
- [31] KAVEH, A., FARHOUDI, N., “A new optimization method: Dolphin echolocation”, May 2013 Advances in Engineering Software 59:53–70. DOI: 10.1016/j.advengsoft.2013.03.004.
- [32] MEHRABIAN, A.R., LUCAS C., “A novel numerical optimization algorithm inspired from weed colonization”, Ecological Informatics 1 (4): 355-366 (2006) DOI:10.1016/j.ecoinf.2006.07.003.

- [33] UYMAZ, S.A., TEZEL, G., YEL E., “Artificial algae algorithm with multi-light source for numerical optimization and applications”, *Biosystems*. 2015 Dec;138:25-38. DOI: 10.1016/j.biosystems.2015.11.004. Epub 2015 Nov 10.
- [34] LI, M.D., ZHAO, H., WENG, X.W., HAN T., “A novel nature-inspired algorithm for optimization: Virus colony search”, *Advances in Engineering Software* 92:65-88, February 2016. DOI: 10.1016/j.advengsoft.2015.11.004.
- [35] ABEDINIA, O., AMJADY, N., GHASEMI, A., “A new metaheuristic algorithm based on shark smell optimization”, *Complexity* Volume 21, Issue 5, 2014. DOI: 10.1002/cplx.21634.
- [36] YU, J.J.Q., LI, V.O.K., “A Social Spider Algorithm for Global Optimization”, *Applied Soft Computing*, 2015, v. 30, p. 614-627. DOI: 10.1016/j.asoc.2015.02.014.
- [37] ERDOĞMUŞ, P., “Doğadan Esinlenen Optimizasyon Algoritmaları ve Optimizasyon Algoritmalarının Optimizasyonu”, *Düzce Üniversitesi Bilim ve Teknoloji Dergisi*, 4 (2016) 293-304.
- [38] LIANG, J.J., QIN, A.K., SUGANTHAN, P.N., BASKAR, S., “Comprehensive learning particle swarm optimizer for global optimization of multimodal functions, *IEEE Transaction on Evolutionary Computation*, Vol. 10(3), pp. 281-295, 2006.
- [39] SEVKLI, Z., SEVILGEN, E., “A Hybrid Particle Swarm Optimization Algorithm for Function Optimization”, *EvoWorkshop’08. LNCS* Vol. 4974, pp. 585-595, 2008.
- [40] VAN DEN BERG, F., ENGELBRECHT, A., “A new locally convergent particle swarm optimizer”, *Proceeding of IEEE Conference on System, Man and Cybernetics*, pp. 96-101, 2002.
- [41] FAN, S.K., ZAHARA, E. “A hybrid simplex search and particle swarm optimization for unconstrained optimization”, *European Journal of Operational Research*, Vol. 181, pp. 527-548, 2007.
- [42] LIU, B., WANG, L., JIN, Y-H., TANG, F., HUANG, D.X., “Improved particle swarm optimization combined with chaos”, *Chaos Solutions & Fractals* Vol.25, pp. 1261-1271, 2005.
- [43] SHELOKAR, P.S., SIARRY, P., JAYARAMAN, V.K. KULKARNI, B.D., “Particle swarm and ant colony algorithms hybridized for improved continuous optimization”, *Applied Mathematics and Computation*, Vol.188, pp.129-142, 2007.
- [44] SEVKLI, A.Z., SEVILGEN F.E., “StPSO: Strengthened particle swarm optimization”, *Turk J. Elec. Eng & Comp Sci*, Vol.18, No.6, 2010, TÜBİTAK. doi:10.3906/elk-0909-18.

Journal of Scientific Perspectives

Volume 4, Issue 2, Year 2020, pp. 123-136

E - ISSN: 2587-3008

URL: <https://ratingacademy.com.tr/ojs/index.php/jsp>

DOI: <https://doi.org/10.26900/jsp.4.010>

Research Article

SMART FARMING- PRECISION AGRICULTURE TECHNOLOGIES AND PRACTICES ¹

*Aylin KIRKAYA **

** Hektaş R&D Center, Gebze Technical University, TURKEY,*

e-mail: aylinkirkaya@hotmail.com

ORCID: <https://orcid.org/0000-0003-0108-1802>

Received: 14 January 2020, Accepted: 17 April 2020

ABSTRACT

According to the current increase rate of the world population it is expected to reach 10 billion people in 2050. In addition, agricultural production area and agricultural labor force is constantly decreasing with the migration of rural population to the city with the use of agricultural areas for residential and industrial purposes. Therefore, it is a necessity to develop and disseminate systematic and efficient production techniques that will provide sufficient nutrition for humanity.

The agricultural sector also benefits greatly from what Industry 4.0 brings. IoT (Internet of Things), AI (Artificial Intelligence), Remote Sensing & ImP (Remote Sensing and Image Processing) techniques have been integrated with GIS (Geographic Information Systems) and have been actively used in agriculture in recent years. In addition to the soil characteristic and meteorological data collected by sensors, high resolution multi-band images taken from satellite systems and unmanned aerial vehicles are transferred to decision support platforms and artificial intelligence support can be used to determine the stress factors of crops and propose instant solution alternatives.

Within the scope of this paper, in a study carried out by HEKTAŞ R & D Center which develops innovation projects in the agricultural sector with the motto of "Pioneer of smart agriculture" general information will be given on the practical use of some of the above mentioned precision agricultural techniques during phenological growth stages of the wheat in Thrace region.

Keywords: *Precision Agriculture, IoT, Spectral analysis, UAV, Artificial Intelligence, Remote sensing*

¹ *This study is the revised form of the manuscript, presented at "3rd International Conference on Awareness" on 5 - 7 December 2019, Çanakkale / TURKEY*

1. INTRODUCTION

Hektaş is a Turkish company which is provider of fertilizer, seed and crop protection products for agriculture sector since 1956 and is a subsidiary company of OYAK group. "The doctor of agriculture" slogan which is used by Hektaş along years has turned to "pioneer of smart agriculture" motto by innovative investment. Within this scope, projects were developed in the R & D Center established within the framework of the vision of taking part in all areas that create added value to the agricultural sector.

The aim of this study is to determine the factors that cause stress on plant growth at early stage and to provide optimal solution through the geographic information system based decision support platform that established within the scope of precision agricultural practices project. There is a necessity to create a spectral library of crops for Turkey's natural planting conditions. It can be done on selected cultivated area by remote sensing and image processing techniques using drones which are equipped with spectral cameras. At Hektaş Research and Development Center, data is collected and analyzed by aforementioned techniques. This library could be reference for further research and practices.

Precision agriculture techniques that allow effective timing and optimized application of inputs have the ability to protect crop health, protect soil and environment, improve efficiency, life quality and sustainability.

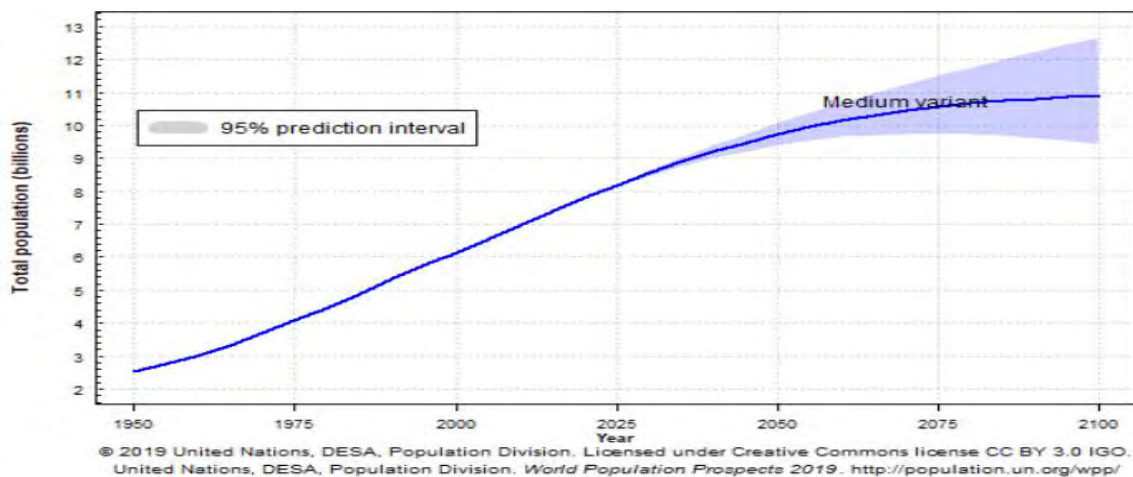
Due to the increasing population and problems to feed them, wheat has been the subject of research as a strategic product. Turkey and world wheat production figures will be mentioned below.

2. WORLD POPULATION AND NUTRITION PROBLEMS

The Food and Agriculture Organization of the United Nations (FAO), World Health Organization (WHO) draws attention to the current situation in its studies and publications and makes predictions about the problems that await us in the future.

Indicators shows that by 2050, we do not have the agricultural production infrastructure to feed the population of 10 billion people worldwide. According to the United Nations Food Safety and Nutrition Report 2019, more than 820 million people are currently under threat of hunger, while 670 million adults and 120 million children are fighting obesity. Along with this unbalanced distribution, it is known that approximately one third of the food is lost or wasted due to various reasons from the beginning of production to consumption.

Graph 1. World population projection



Due to climate change, water resources that are potable and suitable for agriculture are reducing, while natural disasters also increase losses in arable areas.

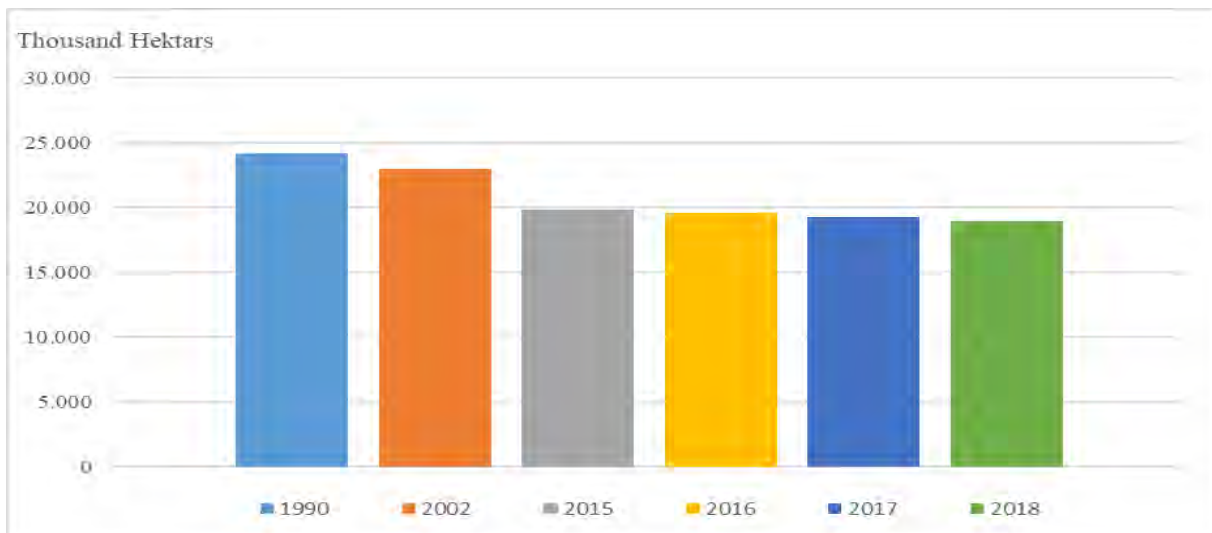
Desertification has become one of the most important environmental problems of today with the impact of climate change, unsustainable fresh water use and land management, which consume resources significantly. 4 billion hectares, which constitute 25% of terrestrial land in the world, directly affect the lives of 1.5 billion people in 193 countries. Every year 12 million hectares of agricultural land is degraded. Agricultural production is expected to decrease by 2% in the next decade. Observations over the past five years show that on average 5.2 million hectares of forest land is decreasing each year. The effect of erosion on the decrease of land productivity in Turkey still stands out as the foremost problem. 59% of agricultural land, 64% of pasture, 54% of forest land are exposed to erosion. Non-agricultural uses (industrial, urbanization, tourism, mining and transportation for public investment) are among the causes of land destruction as well as erosion.

Table 1. Agricultural Land in Turkey

Agricultural land (Thousand hektars)	1990	2002	2015	2016	2017	2018
Sown area of cereal and other crops	18.868	17.935	15.723	15.575	15.498	15.421
Fallow land	5.324	5.040	4.114	3.998	3.697	3.513
Area of vegetable gardens	635	930	808	804	798	784
Area of fruits, beverage and spice crops	3.019	2.674	3.284	3.329	3.343	3.462
Area of ornamental plants	0	0	5	5	5	5
Total utilized agricultural land	27.846	26.579	23.934	23.711	23.341	23.185

Source: Turkish Statistical Institute

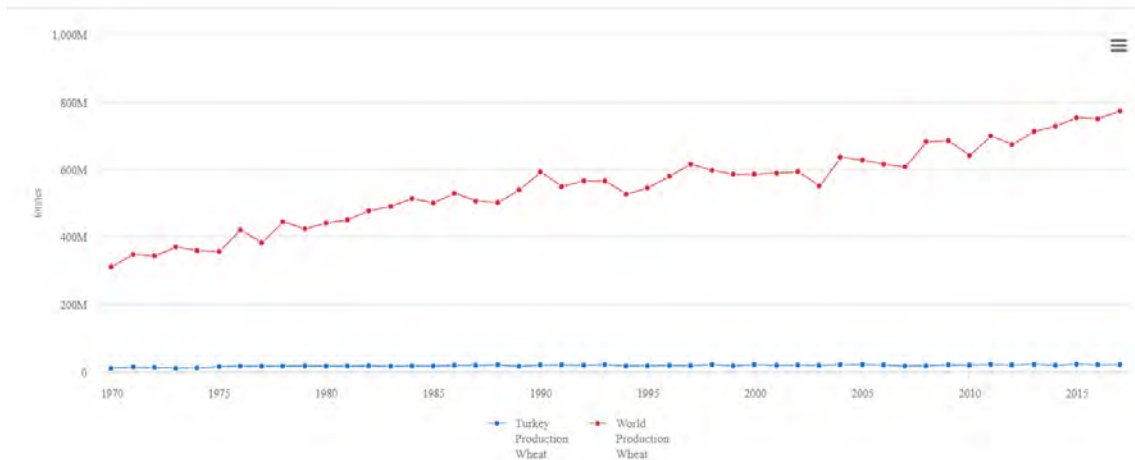
Graph 2. Agricultural Land (cereal&other crops and fallow land) in Turkey by years



Source: Turkish Statistical Institute

The total of sown and fallow area for crop production has decreased by 21.6% in the last 28 years.

Graph 3. Wheat Production of Turkey and World (1970-2017)



Source: Food and Agriculture Organization of United Nation

3. THE FOURTH INDUSTRY REVOLUTION; DIGITALIZATION PROCESS: FROM INDUSTRY 4.0 TO AGRICULTURE 4.0

What do we understand when it comes to industry 4.0?

Mechanical production systems that use water and steam power to assist workers in large-scale manufacturing of products since the late 18th century are called industry 1.0. Industry 1.0 can be considered the beginning of a business culture that focuses on efficiency, quality and scale.

In the early 20th century, electricity was widely used in mass production and adopted as Industry 2.0.

The widespread use of computers and the use of information technologies, electronics and automation systems in 1970 and later are expressed as Industry 3.0.

The concept of Industry 4.0, which covers the concept of "Internet of Things", was used for the first time in 2011 in Hannover Fair. Basically Industry 4.0 Cyber-Physical Systems (a combination of physical and virtual worlds) is based on the Internet of Things and the Internet of Services. Industry 4.0 includes intelligent robots, fully autonomous systems, driverless cars, driverless trucks, captainless ships, pilotless planes, virtual reality, etc. It is the name given to the total digital transformation covering many areas.

Industry 4.0 defines the Fourth Industrial Revolution, a new level in the organization and management of the entire value chain in the life cycle of products and production systems. This cycle focuses on personalized customer demands and includes the entire chain in the product development and production order, from the idea stage to the distribution and recycling of a product to the end user. The effects of Industry 4.0 on the business world are presented in three main areas. These are the integration and digitization of vertical and horizontal value chains, digitalization of products and services, and the creation of a digital business model and customer relationships (Guban & Kovacs, 2017: 113).

The application of developing technology in agriculture was not delayed. The data obtained from the sensors can be analyzed with artificial intelligence and deep learning

methods, and crop protection and nutrition programs can be made. Suggestions made with decision support platforms have started to be adopted by the farmer. Pesticides, herbicides, fertilizers and water can be applied autonomously by the smart agricultural machine or drones only to the area where the stressed plant is located instead of the whole area.

Agriculture 4.0; Data collection methods have been developed with remote sensing, image processing, GPS technology, IoT technologies with sensors. These smart devices and robotic systems and precision agriculture make farms more profitable, productive, safe and environmentally friendly.

4. SMART AGRICULTURE TECHNOLOGIES

Factors that cannot be controlled by the impact of climate change increase the loss of on-farm food in agricultural production. Common causes of losses include restrictions on the use of resources in production practices, improper harvesting techniques, and post-harvest handling and storage. Traditional production methods of farmer cannot provide professional monitoring of plant growth.

Regarding the future of agriculture, a number of adjustment measures should be taken regarding agricultural practices such as sowing, harvesting and irrigation, fertilization of existing plants, seed selection, use of different varieties, diversification of crops and innovative management practices. In digital monitoring methods data collected from channels such as satellite images, ground-based optical sensors, aerial imagery are stored systematically and location-based. The interrelation of the data can be analyzed using various algorithms and ready-to-use information can be transmitted by mobile phones within seconds. Digital technologies that entered our lives with Industry 4.0 serve as intermediaries that provide data to decision support platforms.

The Internet of Things (IoT): It is an internet-based network system where smart devices that communicate with each other by sensors can activate some operations using this information. IoT is quickly accepted in many industries when combined with other technologies due to its real-time, highly sensitive digital information flow and its benefits in process and service management. It is considered that 20 billion devices in many areas such as smart houses, cities, energy systems, communication, logistics, agriculture, health, industry are connected with IoT technology. It is thought to be combined with blockchain technology against security problems.

GIS (Geographical Information Systems) : GIS is described as systems of data that managed based on locations. With GIS that which includes location-based data collection, management and analysis; lots of data could related easily and provide a more in-depth perspective and insights by maps that visualized data.

Artificial intelligence (AI): Artificial intelligence has many definitions, it basically defines a simulation system designed by human and mimicking mind actions. It consists of teaching the system with various algorithms, providing a kind of reasoning ability and increasing the reliability of the output by using the comparison data by continuously feeding the system with an integrated approach. Although the limits of human intelligence are unknown, it needs machine support in multiple, complex and large amount of data processing, and it can use the technology and information system for its purposes. With these systems, decision making mechanism is developed and accelerated.

Hektaş Smart Assistant (AA) mobile application uses artificial intelligence technology to diagnose plant disease by photograph and offer suggestions related to the disease in seconds. AA application is the winner of Growtech Agricultural Innovation Awards in the category of

"Agricultural Informatics" in Growtech Eurasia 2019 - 19th International Greenhouse, Agricultural Technologies and Livestock Equipment Fair.

Remote sensing is expressed as the science and art of learning and analyzing information about the earth and its objects, measured by instruments placed on any platform, at a certain distance, in the atmosphere or on the satellite, without physical contact. It is technically the process of detecting and monitoring the physical properties of regions such as cities, forests, agricultural areas by measuring the reflected and emitted radiation with sensors on planes, satellites and drones.

Image processing is a method of performing some operations on the image to combine many images with the help of appropriate software, make them meaningful and to reach appropriate information. The processed image results can be expressed visually, numerically and graphically after corrections.

5. RESEARCH METHODS AND MATERIALS

5.1. Methodology

Widespread wheat varieties produced in Thrace region, were monitored by remote sensing in approximately 500 hectares in 3 different regions from planting to harvest during the stages of growth and development. The captured images were processed, image analyzes were performed and classified.

5.2. Materials and other requirements

- Unmanned Aerial vehicles; DJI, 2 units (UAV 0 and UAV 1) within the framework of the regulations and permits of the General Directorate of Civil Aviation, are used with the appropriate pilot license.
- Cameras and devices; 4 cameras (multispectral, thermal) and spectroradiometers were used.
- Geographic Information System based decision support platform and various specific software

128

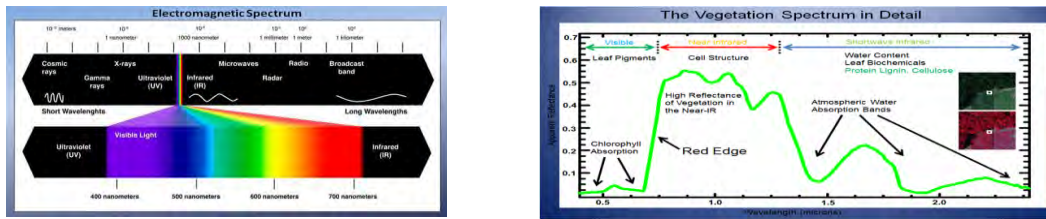
5.3. Remote sensing and image processing

It is possible to obtain information about the development and health of plants by looking at the reflection values at various wavelengths. Images are captured under optimum sunlight condition and flight level using a UAV equipped with a spectral camera.

One of the aims of this research is to determine the unhealthy plant area using spectral images obtained from drones and provide detailed information about the health of the crop, the area covered by the stressed crop and its geographical location.

In this study, a combination of spectral vegetation index techniques was used to produce a comprehensive solution for precision agriculture using image processing.

Figure 1. Spectral analysis fundamentals for agriculture



The Electromagnetic Spectrum. Source: Zami, Zuly.

Details of an example vegetation spectral signature. Source: Mark Elowitz



Source: https://agribotix.com/wp-content/uploads/2016/04/WhatFarmersNeedToKnow_web.pdf

5.3.1. Remote Sensing and Image processing applications in precision agriculture

- Hydrological Evaluations
- Image interpretation: variety identification
- Image interpretation: plant stress detection
- Image interpretation: weed detection
- Determination of yield

5.3.2. Measurable benefits of remote sensing / image processing applications in agriculture

- Provide information to make better management decision
- Reduce chemical and fertilizer costs through more efficient application
- Improve crop yield and profit margin
- Preserve natural resources, reduce pollution
- Food Safety

5.3.3. Commercial use opportunities

- Agricultural products with high economic and strategic value for the country and products with large chronic yields and quality losses
 - Products and areas that cannot be used efficiently due to unconscious production practices
 - Agricultural areas that difficult to manage.

Figure 2. Flow chart of plant protection studies by remote sensing and image processing

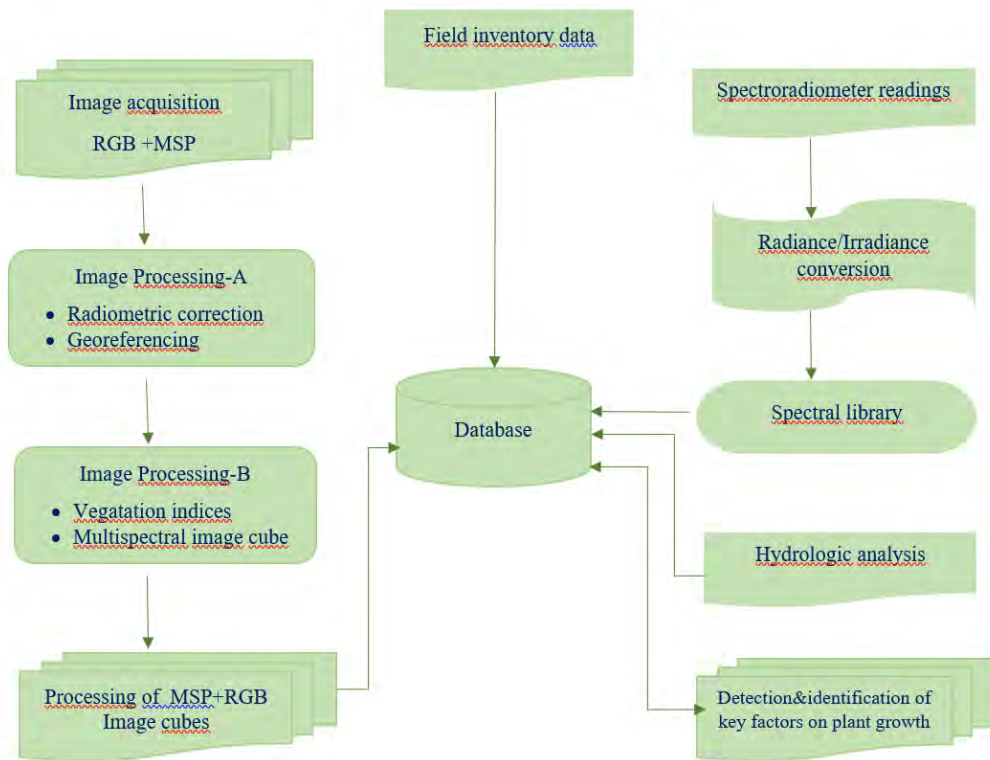


Figure 3. Image Processing of RGB + MSP

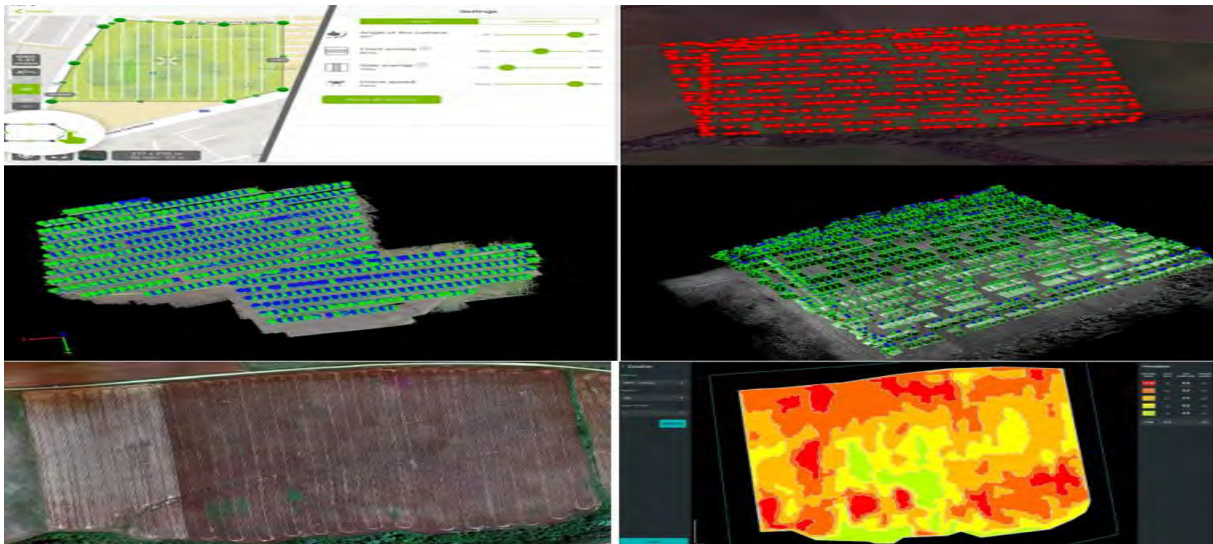


Figure 4. Hydrological evaluations (Digital Elevation and Digital Surface model images)

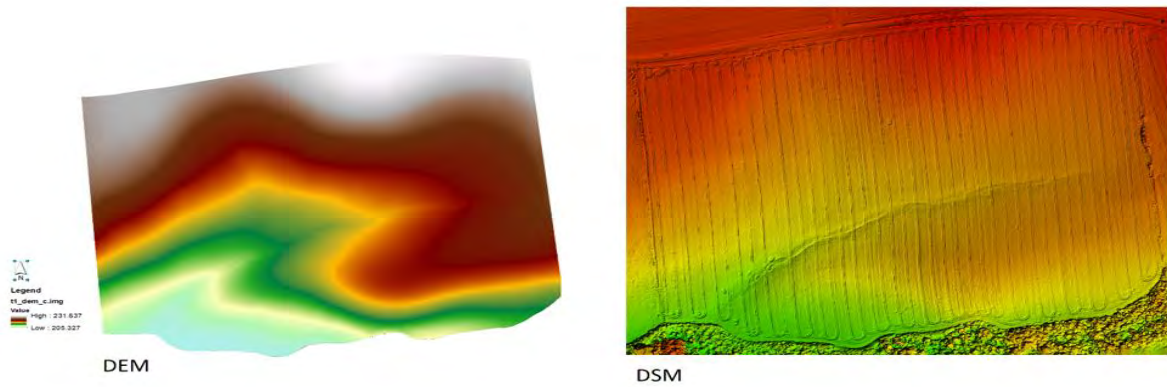
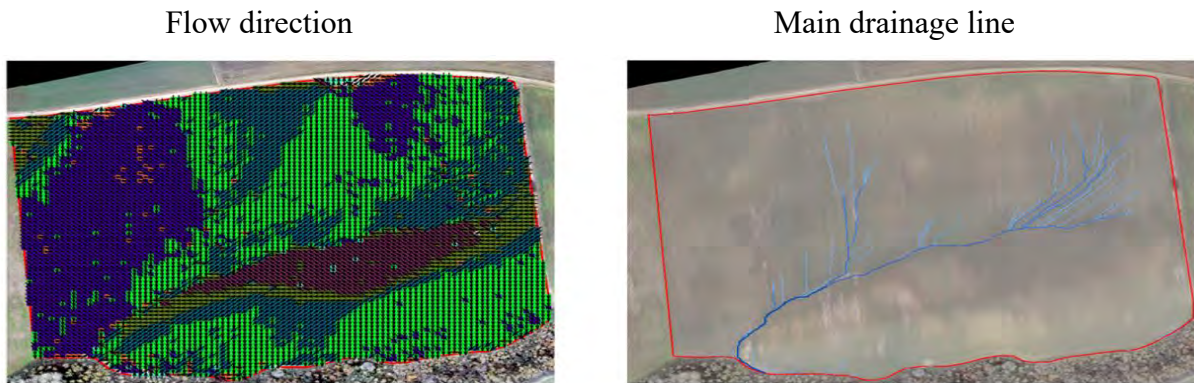


Figure 5. Hydrological Processing Results (Drainage and water flow images)



The presence of water-borne stress conditions can be evaluated and solutions can be offered.

Figure 6. Image interpretation: variety identification

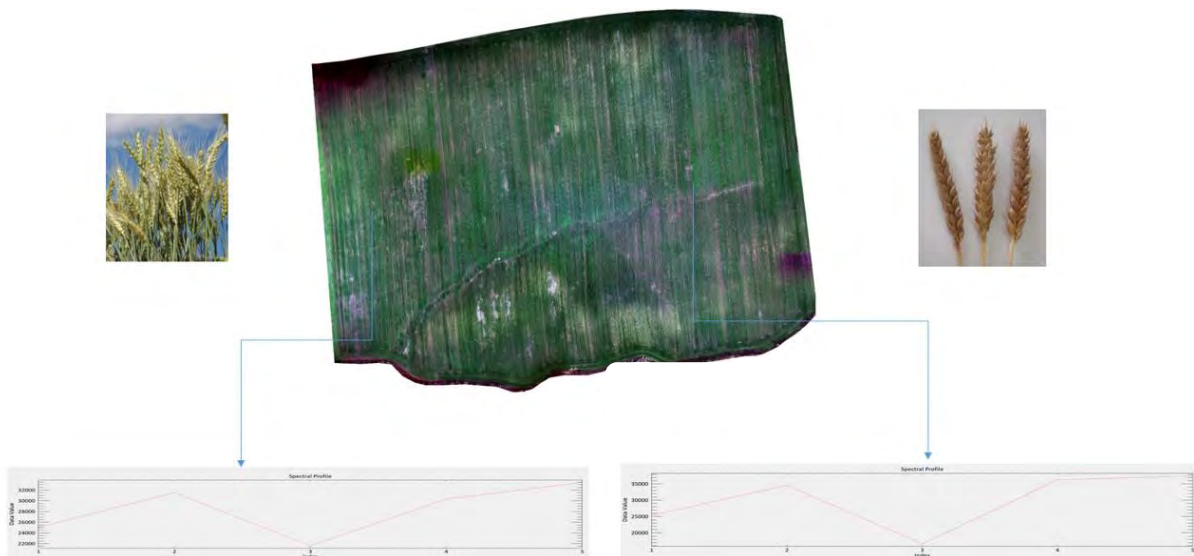


Figure 7. Image interpretation: plant stress detection

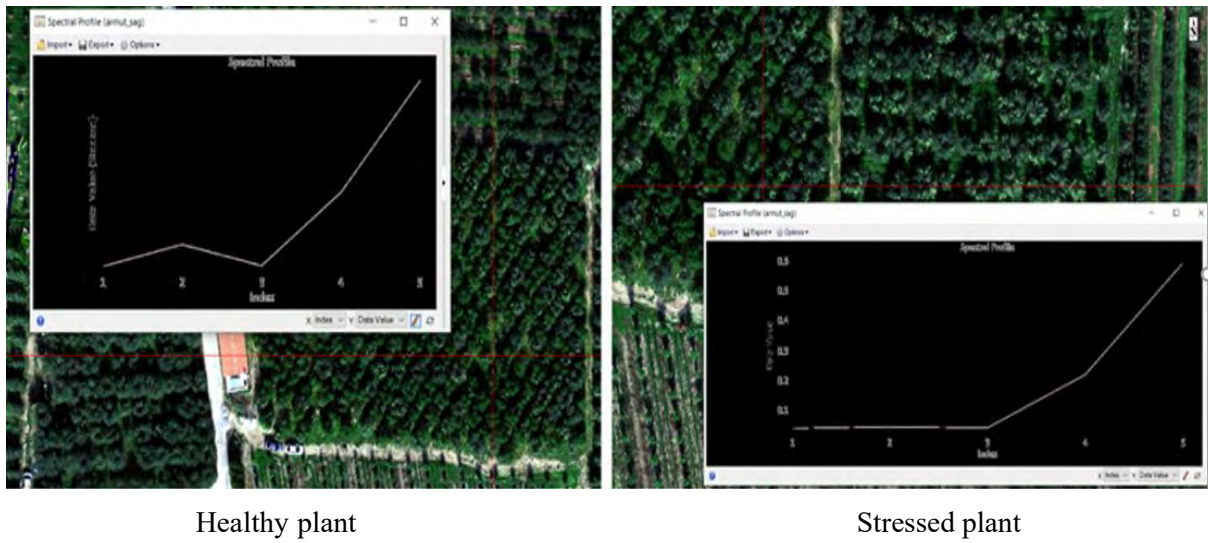
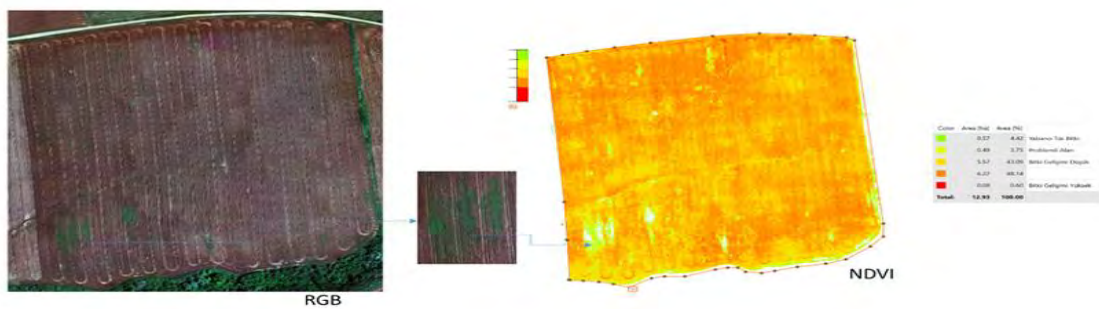
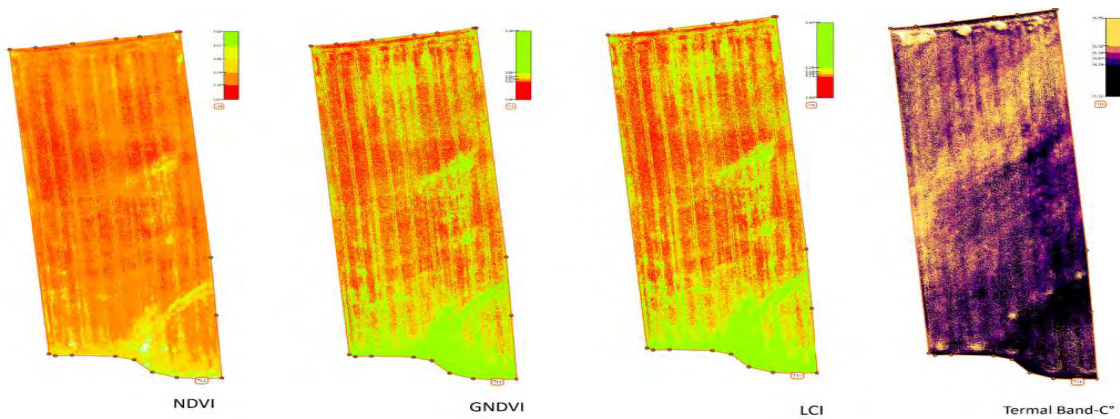


Figure 8. Image interpretation, weed detection



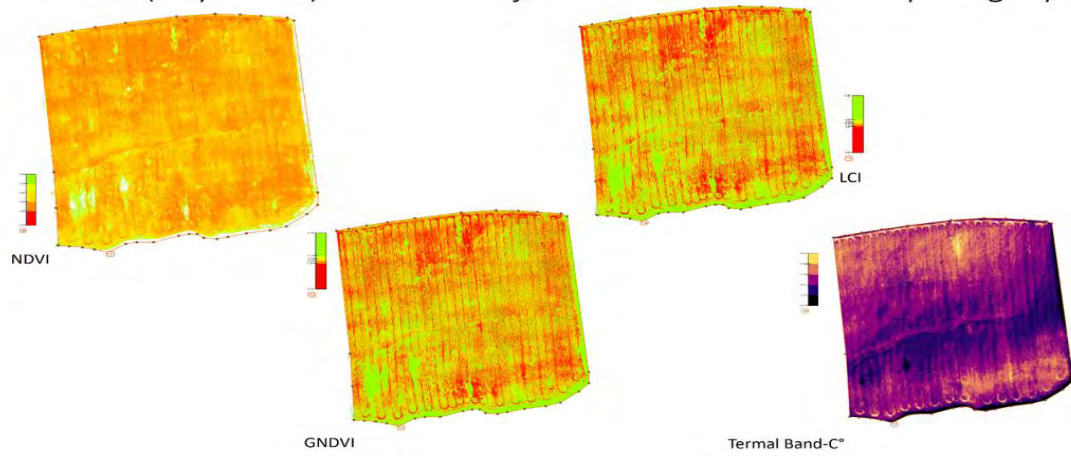
When thousands of images are processed and analyzed, weeds can be detected and location based programming can be done for disposal.

Figure 9. Image interpretation: Field 1- Variety A



Reflectance value varies depending on the variety of plant.

Figure 10. Image interpretation: Field 2- Variety B



Reflectance value varies depending on the variety of plant.

Figure 11. Determination of yield

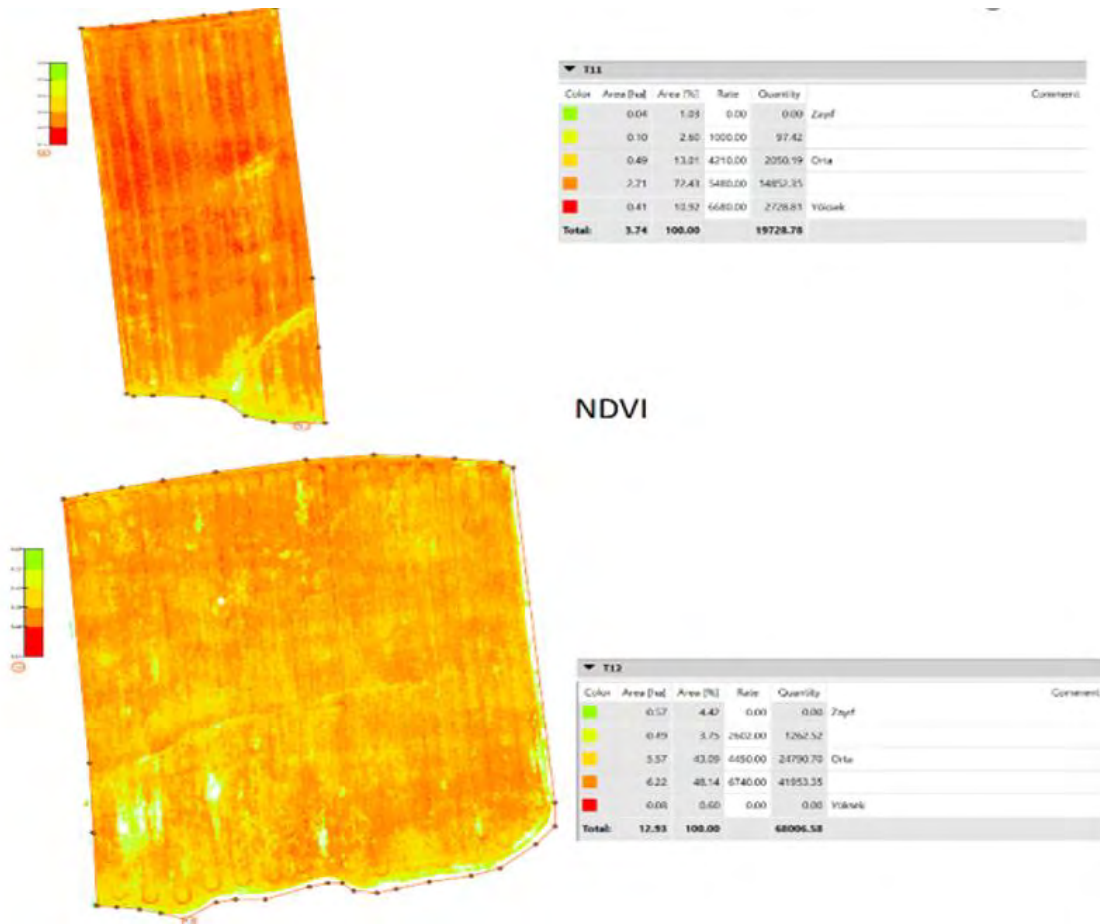
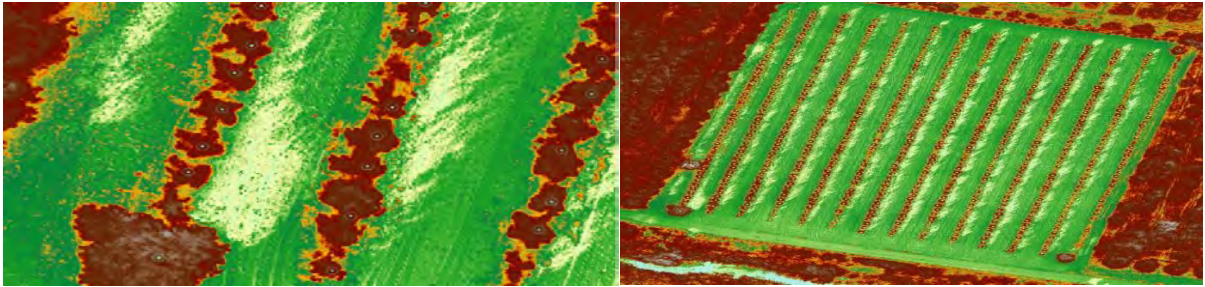


Figure 12. Tree count: 598 pieces



6.CONCLUSION

As a result of this study, the spectral analysis of the wheat plant was made and the spectral library archive started to be created. Parameters affecting plant growth have been added to the location-based database and an information store has been created for analysis to be conducted with deep learning techniques and artificial intelligence support.

Practises are ongoing to create a spectral library of other crops that are grown in different climatic conditions of the country. The research is deepened by establishing an infrastructure to monitor the changes in the biochemical structure of plants under controlled conditions by spectral analysis.

Despite the borders of the countries, the world's natural resources are used by all living things. Optimum use of resources is required for the sustainability of new generations. In the above study, it is clearly seen that the developing technology provides an advantage in the agricultural sector. Its use should be expanded immediately.

Turkey has a unique geographical location. The farming and grain production of the world began in Turkey. The world's first agricultural community lived in Gobeklitepe 12,000 years ago. For this reason, it is essential to implement and pioneer technological development in agriculture.

One of the most important warnings to be considered in the COVID-19 pandemic is that investment and development in the agricultural sector is a priority. Similarly, it is clear that blockchain-like technology infrastructure studies should be added to food safety policies for possible foodborne outbreaks.

REFERENCES

- ABERSFELDER, S., BOGNER, E., HEYDER, A., FRANKEL, J., 2016, *Application and validation of an existing Industry 4.0 guideline for the development of specific recommendations for implementation*, *Advanced Materials Research*, 1140, 465-472.
- Akıllı Tarım Platformu, 2019, *Türkiye’de Akıllı Tarımın Mevcut Durum Raporu*.
- ALBERS, A. & B. GLADYSZ & T. PINNER & V. BUTENKO & T. STURMLINGER, 2016, *Procedure for defining the system of objectives in the initial phase of an industry 4.0 project focusing on intelligent quality control systems*, *Procedia CIRP*, (52), 262-267.
- ALMADA-LOBO, F., 2015, *The Industry 4.0 revolution and the future of Manufacturing Execution Systems (MES)*, *Journal of Innovation Management*, 3(4), 16-21.
- BANERJEE, M., CHOO, K. R., LEE, J., 2018, *A blockchain future for internet of things security: a position paper*, *Digital Communications and Networks*, 4 (3):149-160.
- BARNES, A.P., SOTO, I., EOPRY, V., BARBERO, M.G., 2019, *Exploring the adoption of precision agricultural technologies: A cross regional study of EU farmers*, *Land Use Policy* 80:163-174.
- CHEN, Z., GU, X., HUANG, Y., Yu, T., 2018, *Agricultural remote sensing big data: Management and applications*, *Journal of Integrative Agriculture*, (179), 1915–1931.
- CLIMATE DIPLOMACY, 2019, *Explainer: ‘Desertification’ and the role of climate change* [online], Intergovernmental Panel on Climate Change (IPCC), <https://www.climate-diplomacy.org/news/explainer-%E2%80%98desertification%E2%80%99-and-role-climate-change>, [Date Accessed: 7 October 2019].
- ELOWITZ, M.R., *What is Imaging Spectroscopy (Hyperspectral Imaging)?*, www.markelowitz.com/Hyperspectral.html, [Data Accessed:11 November 2018].
- FOOD AND AGRICULTURE ORGANIZATION OF THE UNITED NATIONS, FAOSTAT, 2019, *Food and Agriculture Data*, <http://www.fao.org/faostat/en/#data/QC>, [Data Accessed:19 November 2019].
- FORESIGHT, 2011, *The Future of Food and Farming*, Foresight Programme, Govt Office for Science, London.
- GEBBERS, R. and ADAMCHUK, V.I., 2010, *Precision Agriculture and Food Security*, *Science* Vol. 327 no. 5967, pp. 828-831.
- GENTNER, S., 2016, *Industry 4.0: Reality, Future or just Science Fiction? How to Convince Today’s Management to Invest in Tomorrow’s Future! Successful Strategies for Industry 4.0 and Manufacturing IT*, *Chimia*, 70 (9): 628-633.
- GRIFFIN, T., BONGIOVANNI, R., LOWEBERG-DEBOER, J., 2010, *Worldwide Adoption of Precision Agriculture Technology: The 2010 Update*, *10th International Conference of Precision Agriculture*, July 18–21, 2010, Denver, Colorado, USA.
- GUBÁN, M. and KOVÁCS G., 2017, *Industry 4.0 Conception*, *Acta Technica Corviniensis Bulletin of Engineering*, 10(1), 111.
- INAN, M., 2004, *Orman Varlığının Saptanmasında Uzaktan Algılama Verileri*, Doktora, İstanbul Üniversitesi.
- KOCA, K.C., 2018, *Sanayi 4.0: Türkiye Açısından Fırsatlar ve Tehditler*, *Sosyoekonomi*, Vol. 26(36), 245-252.

- LU, Y., 2017, *Industry 4.0: A survey on technologies, applications and open research issues*, Journal of Industrial Information Integration, (6), 1-10.
- L3HARRIS GEOSPATIAL, 2013, *Vegetation Analysis: Using Vegetation Indices in ENVI*, <https://www.harrisgeospatial.com/Learn/Whitepapers/Whitepaper-Detail/ArtMID/17811/ArticleID/16162/>, [Date Accessed: 10 November 2018].
- McKINNON, T., 2016, *Agricultural Drones; What Farmers Need to Know*, https://agribotix.com/wp-content/uploads/2016/04/WhatFarmersNeedToKnow_web.pdf, [Data Accessed:13 November 2018].
- PIERPAOLA, E., CARLIA, G., PIGNATTIA E. et al., 2013, *Drivers of Precision Agriculture*
- PREUVENEERS, D., & ILIE-ZUDOR, E., 2017, *The intelligent industry of the future: A survey on emerging trends, research challenges and opportunities in Industry 4.0*, Journal of Ambient Intelligence and Smart Environments, 9(3):287-298.
- PRICE WATERHOUSE COOPERS INTERNATIONAL LIMITED COMPANY, 2016, 2016 Global Industry 4.0 Survey: Industry 4.0: Building the digital enterprise, <https://www.pwc.com/gx/en/industries/industries4.0/landing-page/industry-4.0-building-your-digitalenterprise-april-2016.pdf>, [Data Accessed:25 November 2019].
- TEKE ve diğ., 2016, Akıllı Tarım Fizibilite Projesi: Hassas Tarım Uygulamaları İçin Havadan Ve Yerden Veri Toplanması, İşlenmesi Ve Analizi, 6. *Uzaktan Algılama-Cbs Sempozyumu (Uzal-Cbs 2016)*, 5-7 Ekim 2016, Adana.
- TEMA VAKFI, 2019, Toprağımız için elele, http://www.tema.org.tr/web_14966-2_1/entitalfocus.aspx?primary_id=2179&target=categorial1&type=2&detail=single, [Date Accessed: 21 July 2019].
- TRAKYA KALKINMA AJANSI Planlama, Programlama ve Koordinasyon Birimi, 2014, *Çiftçi Algısı Analizi*, Kalitatif Rapor Çiftçi Odak Grup Toplantıları, Edirne, https://www.trakyaka.org.tr/upload/Node/33084/xfiles/Ciftci_Algisi_Analizi_Kalitatif_Rapor2.pdf, [Date Accessed: 3 November 2018]
- TURKISH STATISTICAL INSTITUTE, 2019, Statistic by Theme, Agriculture, <http://www.tuik.gov.tr/UstMenu.do?metod=kategorist>, [Data Accessed:26 October 2019].
- UNITED NATIONS, DESA, 2019, Population Division, World Population Prospects 2019, <https://population.un.org/wpp/Graphs/Probabilistic/POP/TOT/900>, [Data Accessed:12 November 2019].

Journal of Scientific Perspectives

Volume 4, Issue 2, Year 2020, pp. 137-146

E - ISSN: 2587-3008

URL: <https://ratingacademy.com.tr/ojs/index.php/jsp>

DOI: <https://doi.org/10.26900/jsp.4.011>

Research Article

**AN EVALUATION OF A CONSTRAINED MULTI-OBJECTIVE
GENETIC ALGORITHM**

Youssef ALIOUI & Reşat ACAR***

** Ph.D. Student, Atatürk University,
TURKEY, e-mail: youssef.alioui14@ogr.atauni.edu.tr
ORCID: <https://orcid.org/0000-0003-2915-6917>*

*** Prof. Dr. Atatürk University,
TURKEY, e-mail: racar@atauni.edu.tr
ORCID: <https://orcid.org/0000-0002-0653-1991>*

Received: 30 December 2019, Accepted: 12 May 2020

ABSTRACT

Real world optimization problems involve multiple conflicting objectives (such as minimizing cost while maximizing the quality of a product) and are subject to constraints (such as physical feasibility or budget limitations) which makes them interesting to solve. Over the last decades, evolutionary algorithms have been largely used in solving optimization problems in various fields of science. The aim of this study is to evaluate the performance of a constrained version of the Non-dominated Sorting Genetic Algorithm 2 (NSGA 2), a multi-objective evolutionary optimization algorithm, written in MATLAB. The developed NSGA 2 is compared, in terms of convergence and diversity of the obtained solutions, to a number of popular constrained multi-objective evolutionary algorithms from the literature. Widely used four benchmark problems (including CONSTR, OSY, SRN, and TNK problems) with varying difficulty and type of constraints are reviewed and used. The NSGA 2 obtained the lowest values of inverse generational distance (IGD) values for almost all the problems. These results show that the developed constrained NSGA 2 is an effective technique and is competitive to the other optimization methods in the literature.

Keywords: *Genetic algorithms, Evolutionary algorithms, Non-dominated Sorting Genetic Algorithm 2, Multi-objective optimization, constrained multi-objective optimization.*

1. INTRODUCTION

Solving multi-objective optimization problems have interested researchers in all the fields of science over the last decades. Real world optimization problems usually involve multiple objectives and are subject to constraints. Multi-objective optimization problems have multiple solutions which produce trade-offs between the objectives. A multi-objective optimization problem can be mathematically formulated, without loss of generality, as follows:

$$\begin{aligned} & \text{minimize } F(x) = (f_1(x), \dots, f_m(x)) \\ & \text{subject to } g_i(x) \geq 0, \quad i = 1, \dots, q \\ & x \in \mathbb{R}^n \end{aligned}$$

A solution x is feasible if it satisfies all the constraints simultaneously.

A solution x_1 is said to dominate a solution x_2 if both of the following conditions are true:

- For all the objectives $f_i(x_1) \leq f_i(x_2)$
- There exists at least one objective where $f_i(x_1) < f_i(x_2)$

A solution is said to be non-dominated if it is not dominated by any other solution. The set of non-dominated solutions is referred to as the Pareto optimal set, the image of this set in the objective space is called the Pareto front

In multi-objective optimization our goal is to find as many pareto optimal solutions as possible. classical methods work with a single solution which will require multiple runs while expecting to find a different solution each time. Evolutionary algorithms work with a population of solutions so multiple pareto solutions can be found on a single run which make them suitable to solve this type of problems. Over the last decades a variety of constrained evolutionary algorithms have been presented. We can cite the following algorithms: Adaptive tradeoff model (ATM) by (Wang, Cai, Zhou, & Zeng, 2008), Infeasibility Driven Evolutionary Algorithm (IDEA) by (Ray, Singh, Isaacs, & Smith, 2009), Self- adaptive penalty (SP) by (Woldesenbet, Yen, & Tessema, 2009), the MOEA/D-IEpsilon by (Fan et al., 2016) and the non-dominated sorting genetic algorithm (NSGA 2) by (Deb, Pratap, Agarwal, & Meyarivan, 2002) which we will be using in our study.

In this study a constrained NSGA 2 was written in Matlab. A sensitivity analysis was performed to determine the best parameters for the algorithm. In the end the performance of the algorithm was evaluated against other algorithms from the literature.

2. MATERIALS AND METHODS

Before describing the main loop of the NSGA 2, we are going to present the main procedures of the algorithm: non-dominated sorting, crowding distance, the crowded comparison operator and the constraint handling technique.

2.1 Non-Dominated Sorting

This method was first introduced by (Deb et al., 2002). The objective of this procedure is to sort the population into different nondomination levels. In the beginning we define and calculate two substances:

- For each solution p we calculate the number of solutions dominating p and we note it as np the domination count.
- All the solutions that the solution p dominates are grouped in a set S_p noted as domination set of p .

Solutions with a domination count $n_p=0$ will form the first nondominated front. For each solution p of this front we reduce the domination count of the members of its domination set by one. Elements whose domination count became zero are put in separate set Q , this set is the second nondominated front. Q undergoes the same procedure to identify the third front. this operation is repeated until all the fronts are determined.

2.2 Crowding Distance (Diversity Preservation)

Solutions obtained by the evolutionary algorithm are desired to be diverse and well dispersed along the Pareto front. to preserve diversity in the obtained solutions (Deb et al., 2002) introduced a parameterless diversity preservation technique. In this technique each solution is assigned a crowding distance which can be calculated as follows:

- For each objective function we sort the population in an ascending order, and assign an infinite distance value to the boundary solutions,
- For the in-between solutions we attribute the absolute normalized difference of function values of the two neighboring solutions. This is repeated for all the objective functions,
- The crowding-distance is the sum of distances calculated for each objective function.

It is beneficial to note that a solution with a bigger crowding-distance is less crowded by other solutions.

After the assignment of the crowding distance, every two solutions can be compared using the crowded-comparison operator as follows:

- If they have different nondomination ranks, the one with smaller rank is selected,
- If they have the same nondomination rank, the one with the bigger crowding distance is selected.

2.3 Constraint Handling

constraint handling is critical in solving constrained optimization problems. To handle the constraints a penalty function based technique is widely used, it converts the problem to an unconstrained optimization problem by adding a penalty to the objective function value for every constraint violation. The quality of obtained results depends highly on the choice of the penalty values. Other efficient methods have been successfully applied such as the Ray-Tai-Seow's method (Ray, Tai, & Seow, 2001) and the Constrained tournament method (Deb et al., 2002). In our study we are going to use the latter, this method is applied in the binary tournament selection process where the following rules are followed:

- If both solutions are feasible select the solution with better fitness,
- If one is feasible and the other is not select the feasible one,
- If both solutions are infeasible select the solution with smaller constraint violation,

2.4 Genetic Operators (Selection, Crossover, Mutation)

Selection operator chooses the chromosomes that will generate the next generation. Various selection methods have been presented in the literature: Roulette Wheel Selection, Tournament Selection, Rank Selection.

chromosomes selected by the selection process undergo crossover to provide child chromosomes, which might have better fitness values. In the crossover process two individuals are selected and some parts of these individuals are exchanged to create new individuals called child chromosomes. A variety of crossover techniques have been presented in the literature: one-point crossover, uniform crossover, two point crossover for the binary representation of chromosomes. random crossover, arithmetic crossover, BLX-alpha crossover, simulated binary

crossover for real presentation of chromosomes.

Mutation operator modify a gene of a chromosome randomly, it is applied with a low probability. This operator introduces new material to the population and prevents premature convergence.

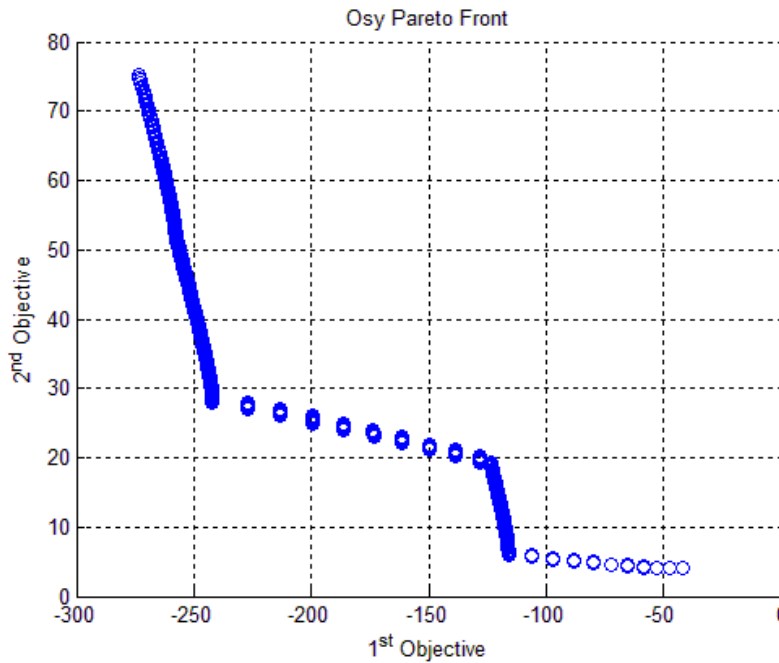
These genetic operators have been detailed by (Kalyanmoy, 2001) and (Goldberg, 1989).

2.5 Test problems

To test the performance of the elaborated algorithm we are going to use the following benchmark problems:

Osyc proposed by (Osyczka & Kundu, 1995), the Pareto front is a concatenation of five regions which lies on the intersection of certain constrains, which requires the algorithm to maintain solutions at the different regions which makes the problem difficult to solve. The Pareto front of the problem is shown in figure 1.

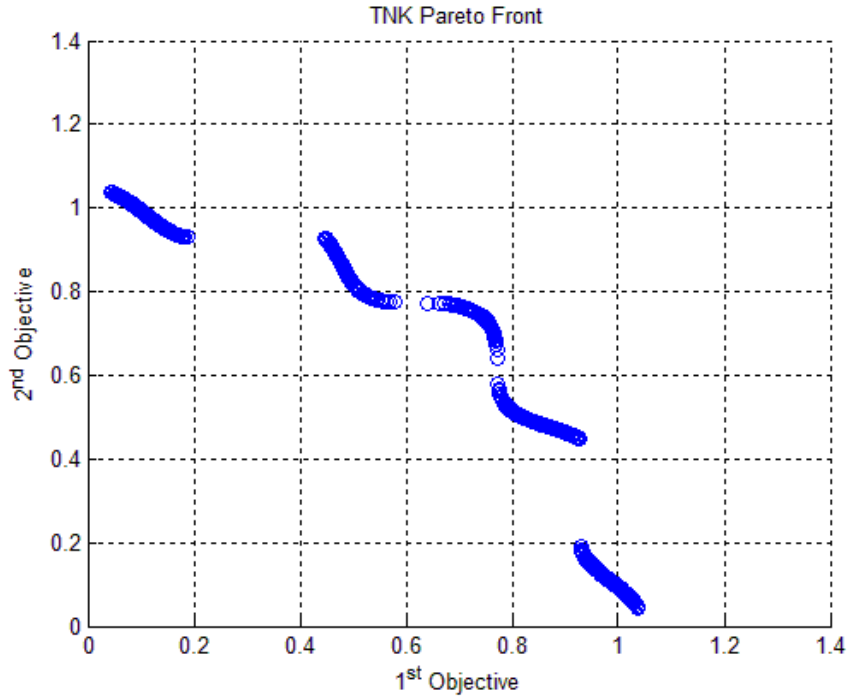
Figure 1. Osy problem's Pareto Front



$$\begin{cases}
 \text{OSY:} \left\{ \begin{array}{l}
 \text{Minimize } f_1(x) = -(25(x_1 - 2)^2 + (x_2 - 2)^2 + (x_3 - 1)^2 + (x_4 - 4)^2 + (x_5 - 1)^2) \\
 \text{Minimize } f_2(x) = x_1^2 + x_2^2 + x_3^2 + x_4^2 + x_5^2 + x_6^2 \\
 \text{Subject to } x_1 + x_2 - 2 \geq 0 \\
 6 - x_1 - x_2 \geq 0 \\
 2 - x_1 + x_1 \geq 0 \\
 2 - x_1 + 3x_2 \geq 0 \\
 4 - (x_3 - 3)^2 - x_4 \geq 0 \\
 (x_5 - 3)^2 + x_6 - 4 \geq 0 \\
 0 \leq x_1, x_2, x_6 \leq 10 \\
 1 \leq x_3, x_5 \leq 5 \\
 0 \leq x_4 \leq 6
 \end{array} \right.
 \end{cases}$$

TNK proposed by (Tanaka, Watanabe, Furukawa, & Tanino, 1995), the fact that the Pareto front is composed of disconnected sets and lies on a non linear constraint surface makes it difficult to find solutions spread across the entire Pareto front. The Pareto front of the problem is shown in figure 2.

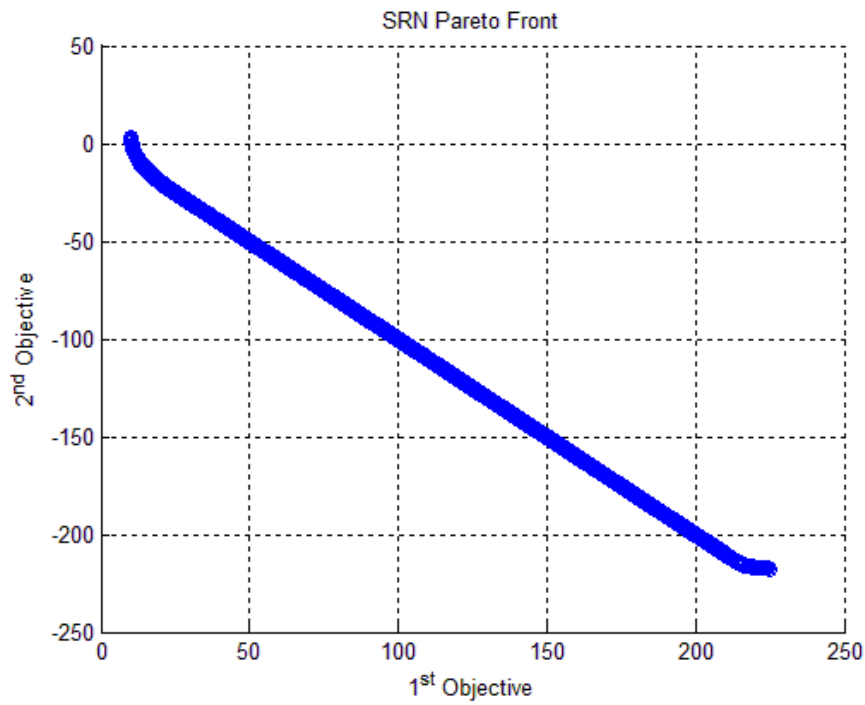
Figure 2. TNK problem's Pareto Front



$$\text{TNK:} \left\{ \begin{array}{l} \text{Minimize } f_1(x) = x_1 \\ \text{Minimize } f_2(x) = x_2 \\ \text{Subject to } x_1^2 + x_2^2 - 1 - 0.1 \cos \left(16 \arctan \left(\frac{x_1}{x_2} \right) \right) \geq 0 \\ \quad \quad \quad (x_1 - 0.5)^2 + (x_2 - 0.5)^2 \leq 0.5 \\ \quad \quad \quad 0 \leq x_1 \leq \pi \\ \quad \quad \quad 0 \leq x_2 \leq \pi \end{array} \right.$$

SRN proposed by (Srinivas & Deb, 1994) , the constraints of this problem eliminate a part of the unconstrained Pareto-Optimal front which make it difficult to solve. The Pareto front of the problem is shown in figure 3.

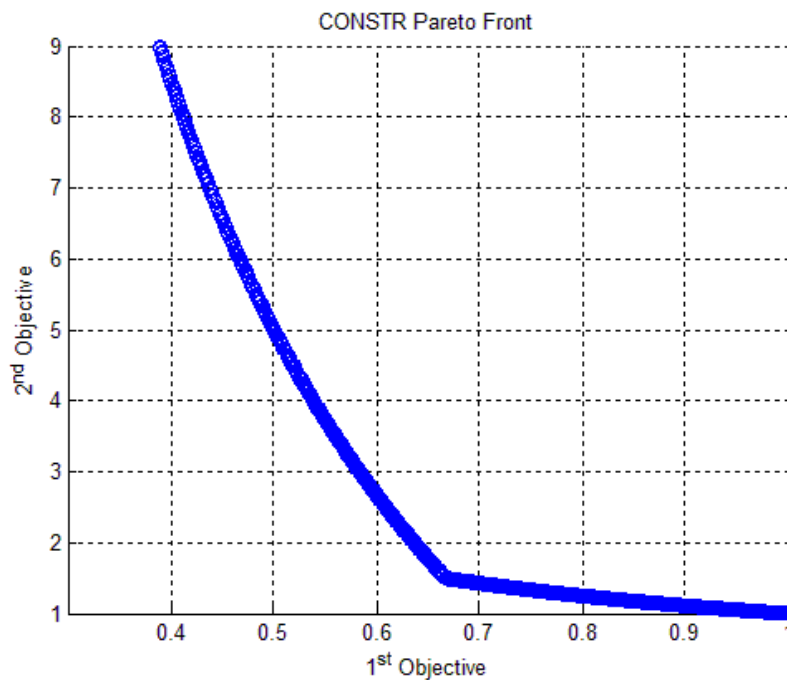
Figure 3 SRN problem's Pareto Front



$$\text{SRN:} \left\{ \begin{array}{l} \text{Minimize } f_1(x) = 2 + (x_1 - 2)^2 + (x_2 - 1)^2 \\ \text{Minimize } f_2(x) = 9x_1 - (x_2 - 1)^2 \\ \text{Subject to } x_1^2 + x_2^2 \leq 225 \\ \quad \quad \quad x_1 - 3x_2 + 10 \leq 0 \\ \quad \quad \quad -20 \leq x_1 \leq 20 \\ \quad \quad \quad -20 \leq x_2 \leq 20 \end{array} \right.$$

CONSTR-Ex proposed by (Deb et al., 2002), in this problem the Pareto front is a concatenation of the first constraint boundary and a some part of the unconstrained pareto front. The Pareto front of the problem is shown in figure 4.

Figure 4 CONSTR-EX problem's Pareto Front



$$\text{CONSTR: } \left\{ \begin{array}{l} \text{Minimize } f_1(x) = x_1 \\ \text{Minimize } f_2(x) = \frac{1 + x_2}{x_1} \\ \text{Subject to } x_2 + 9x_1 \geq 6 \\ \quad \quad \quad -x_2 + 9x_1 \geq 1 \\ \quad \quad \quad 0.1 \leq x_1 \leq 1 \\ \quad \quad \quad 0 \leq x_2 \leq 5 \end{array} \right.$$

2.6 Performance Criteria

In multi-objective optimization we aim to have solutions as close to the Pareto optimal front and spread as possible along the obtained nondominated front. To evaluate the performance of our algorithm we have used the inverse generational distance (IGD). This metric is able to assess the convergence and the diversity of the obtained solutions simultaneously. It is defined as the average of the minimum Euclidean distance between elements of the obtained non dominated front and the optimal Pareto front. A small value of the generational distance means a better convergence toward the Pareto optimal front and a diverse set.

3. RESULTS AND DISCUSSION

To select parameters of the algorithm (crossover probability, crossover technique, mutation probability, population size) a sensitivity analysis has been performed and the following parameter values have been selected:

- Crossover probability: 0.9
- Crossover technique: Blx- α and $\alpha=0.5$
- Mutation probability: 0.05
- Population size: 150
- Iterations number: 1000

Real Pareto front values of the used problems were obtained from (Coello, Lamont, & Van Veldhuizen, 2007). The algorithm was run 30 independent times. Results obtained by the NSGA 2 are illustrated in figure 5 we can conclude that the algorithm converged for all the four problems.

Figure 5 Real Pareto Front vs Obtained Pareto Front

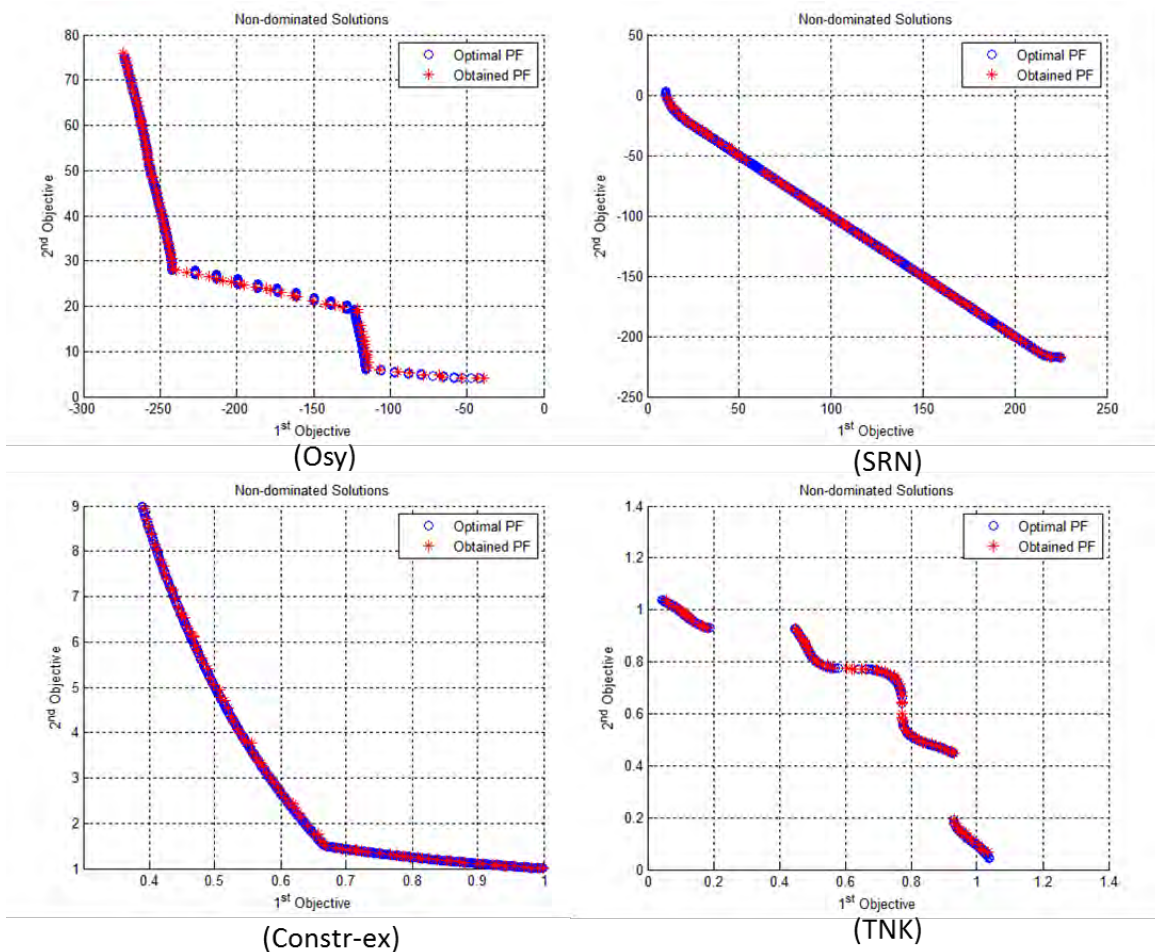


Table 1 shows the mean and variance of the inverse generational distance obtained by (Fan et al., 2017) and those we obtained by the algorithm we developed for the resolution of the four problems.

Table 1 Performance of the algorithms in terms of the mean and standard deviation values of IGD

		ATM	CMOEA/D	IDEA	MOEA/D-CDP	MOEA/D-SR	NSGA-II-CDP	SP	MOEA/D-Epsilon	Our NSGA II
CONTR	mean	1.22E-02	2.33E-02	1.09E-02	2.33E-02	4.52E-02	1.36E-02	1.22E-02	1.28E-02	5.18E-03
	variance	3.69E-03	5.28E-05	2.72E-04	5.70E-05	7.17E-03	7.74E-03	6.31E-03	1.29E-03	1.78E-07
OSY	mean	1.16E+01	1.16E+01	2.75E+00	1.20E+01	1.92E+01	1.14E+01	1.15E+01	4.31E+00	1.10E+00
	variance	1.04E+00	3.79E+00	1.73E+00	4.77E+00	4.13E+00	1.35E+00	8.60E-01	8.67E-01	1.19E-02
SRN	mean	5.08E-01	1.05E+00	6.53E-01	1.08E+00	1.06E+00	5.13E-01	5.11E-01	3.56E-01	1.73E-01
	variance	1.15E-02	5.59E-02	2.37E-02	4.58E-02	5.71E-02	1.78E-02	1.31E-02	8.26E-03	1.11E-03
TNK	mean	4.33E-03	2.52E-03	2.52E-03	2.53E-03	2.69E-02	8.09E-03	4.12E-03	1.82E-03	3.18E-03
	variance	1.01E-03	4.13E-05	7.43E-05	3.60E-05	3.25E-03	4.47E-03	9.48E-04	4.47E-05	6.07E-08

The NSGA 2 outperformed the other algorithms for all the problems except for the TNK where the MOEA/D-Epsilon (Fan et al., 2016) had the best IGD. This indicates that the NSGA 2 is still a powerful tool in constrained optimization problems.

REFERENCES

- COELLO, C. A. C., LAMONT, G. B., & VAN VELDHUIZEN, D. A. (2007). *Evolutionary algorithms for solving multi-objective problems* (Vol. 5): Springer.
- DEB, K., PRATAP, A., AGARWAL, S., & MEYARIVAN, T. (2002). A fast and elitist multiobjective genetic algorithm: NSGA-II. *IEEE Transactions on Evolutionary Computation*, 6(2), 182-197. doi:Pii S 1089-778x(02)04101-2 Doi 10.1109/4235.996017
- FAN, Z., LI, H., CAIMIN, W., LI, W., HAN, H., CAI, X., & CAI, Z. (2016, 6-9 Dec. 2016). *An improved epsilon constraint handling method embedded in MOEA/D for constrained multi-objective optimization problems*. Paper presented at the 2016 IEEE Symposium Series on Computational Intelligence (SSCI).
- FAN, Z., YI, F., LI, W., JIEWEI, L., CAI, X., & CAIMIN, W. (2017, 5-8 June 2017). *A comparative study of constrained multi-objective evolutionary algorithms on constrained multi-objective optimization problems*. Paper presented at the 2017 IEEE Congress on Evolutionary Computation (CEC).
- GOLDBERG, D. E. (1989). *Genetic Algorithms in Search, Optimization and Machine Learning*: Addison-Wesley Longman Publishing Co., Inc.
- KALYANMOY, D. (2001). *Multi-Objective Optimization Using Evolutionary Algorithms*: John Wiley & Sons, Inc.
- OSYCZKA, A., & KUNDU, S. (1995). A New Method to Solve Generalized Multicriteria Optimization Problems Using the Simple Genetic Algorithm. *Structural Optimization*, 10(2), 94-99. doi:Doi 10.1007/Bf01743536
- RAY, T., SINGH, H. K., ISAACS, A., & SMITH, W. (2009). Infeasibility Driven Evolutionary Algorithm for Constrained Optimization. In E. Mezura-Montes (Ed.), *Constraint-Handling in Evolutionary Optimization* (pp. 145-165). Berlin, Heidelberg: Springer Berlin Heidelberg.
- RAY, T., TAI, K., & SEOW, K. C. (2001). MULTIOBJECTIVE DESIGN OPTIMIZATION BY AN EVOLUTIONARY ALGORITHM. *Engineering Optimization*, 33(4), 399-424. doi:10.1080/03052150108940926
- SRINIVAS, N., & DEB, K. (1994). Multiobjective Optimization Using Nondominated Sorting in Genetic Algorithms. *Evolutionary Computation*, 2(3), 221-248. doi:10.1162/evco.1994.2.3.221
- TANAKA, M., WATANABE, H., FURUKAWA, Y., & TANINO, T. (1995). GA-based decision support system for multicriteria optimization. *1995 Ieee International Conference on Systems, Man and Cybernetics, Vols 1-5*, 1556-1561.
- WANG, Y., CAI, Z., ZHOU, Y., & ZENG, W. (2008). An Adaptive Tradeoff Model for Constrained Evolutionary Optimization. *IEEE Transactions on Evolutionary Computation*, 12(1), 80-92. doi:10.1109/TEVC.2007.902851
- WOLDESENBET, Y. G., YEN, G. G., & TESSEMA, B. G. (2009). Constraint Handling in Multiobjective Evolutionary Optimization. *IEEE Transactions on Evolutionary Computation*, 13(3), 514-525. doi:10.1109/TEVC.2008.2009032

Journal of Scientific Perspectives

Volume 4, Issue 2, Year 2020, pp. 147-156

E - ISSN: 2587-3008

URL: <https://ratingacademy.com.tr/ojs/index.php/jsp>

DOI: <https://doi.org/10.26900/jsp.4.012>

Research Article

THE EFFECT OF THERMAL POWER PLANT FLY ASH IN GRANITE BODY ON MICROSTRUCTURE AND TECHNICAL PROPERTIES

*Savaş ELMAS**

** Assist. Prof. Dr. Canakkale Onsekiz Mart University, Fine Arts Faculty,
TURKEY, e-mail: savaselmaz@comu.edu.tr*

ORCID: <https://orcid.org/0000-0003-2913-0303>

Received: 17 February 2020, Accepted: 12 May 2020

ABSTRACT

In this study 2-5-10 wt.% thermal power plant ash was added to the granite body replace feldspar to use environmental waste in the ceramic body and to reduce production costs. Loss on ignitions, fired bending strengths, dry strength, fired shrinkages, water absorption and colorimeter degrees were measured. Microstructure was determined by scanning electron microscope (SEM), energy dispersive x-ray spectrometer (Edx) and x-ray diffractometer (XRD) measurements. After sintering, it was determined that 2 wt.% fly ash can be used in granite body. In sintered body, according to XRD phase analysis, amount of free quartz and mullite decreased and albite formation was observed. While the fired strength value is 399 kg/cm² in standard body, it is 315 kg/cm² in 2 wt.% fly ash added body. In the experiment with 2 wt.% ash additive, according to SEM images, the number and volume of large pores increased while small pores decreased. The ability of pressing of the sample with 10wt.% ash additive was negatively affected due to the excess amount of fine ash and so occur lamination and bloating.

Keywords: *Fly ash, granite, sintering, feldspar, microstructure.*

1. INTRODUCTION

Reuse of waste is very important for conservation of natural resources and a livable environment. In the ceramic industry, many solid wastes are used in ceramic bodies. Some of these are the use of granite cutting wastes in industrial porcelain bodies (Luz and Ribeiro, 2007), use of sewage waste in ceramic floor tiles (Amin et al., 2018), use of fired wall tile's scraps in floor tile body (Elmas, 2019), preparation of ceramic tiling from blast furnace slag (Ozturk and Gultekin, 2015), processing of unglazed ceramic tiles from blast furnace slag (Ozdemir and Yilmaz, 2006), effect of fly ash on the properties of ceramics from steel slag (Zong et al., 2018).

Coal-fired thermal power plant's fly ash waste with worldwide annual cause 600 million tons, 13 million tons in Turkey. (Türkiye'deki Uçucu Küllerin Sınıflandırılması ve Özellikleri dergi, 2009). Many studies on the use of fly ash are available in the literature. The study made by Koçkal (2) was used fly ash replace feldspar according to 5-10-15-20 w.%. The usage of fly ash in big quantities at high temperature is seen bloating in the body. With increasing ash amount, fired shrinkage decreases. The fired strength value is increased up to 10% ash addition in 1190 °C firing. The water absorption value increases up to 10% in fly ash and then decreases. At the sintering temperature, the shrinkage rate decreases with increasing ash content. In the same study, when the amount of ash was increased up to 10%, the amount of water absorption in the body increased. Trnik et al. in a study that contain clay, grog and 20 wt.% of the ash, the elastic modulus of the sample was found to increase rapidly at increasing temperatures where fired shrinkage value is 24%. According to Figen et al. in the study on the use of ash in tile products with fired tile waste, it was found that the use of ash at a rate of 5 wt.% contributed positively to the physical and mechanical properties. Dry strength value and dry shrinkage value decrease with increasing amount of ash. In the addition of 5wt.% ash, the reduction in firing shrinkage in firing at 900-950-1000-1025 °C was found to be less than in the sample without ash. Dana et al. in a study made by kaolin-quartz and feldspar system, quartz was replaced with ash in 5-10-15 wt% and sintered at 1150 -1300 °C. An increase in the density of the ash-containing sample was observed at all temperatures. While the maximum bending strength was found to be 70.5 MPa at 15% ash content at 1300 °C, the fired strength of standard porcelain body is 61.1 MPa. In the XRD measurement, more mullite was observed in the ash containing sample. In SEM measurements, 25-50 micron quartz grains and secondary mullite needles were observed in the glassy matrix. In the study on the production of ceramic tiles with high alumina content from coal fly ash, it was found that the body, which contains 60% fly ash and 4% quartz, has a breaking strength of 51.28 MPa at 1200 °C (Ji et al, 2016). In the same study, water absorption, apparent porosity and linear drawing values were found to exceed the desired value for porcelain tiles. In the study on producing ceramic wall tiles from blast furnace slag, the trial of 33% blast furnace slag has been of high fired strength (Ozturk and Gultekin, 2015). The addition of a high calcium glassy phase structure led to the growth of anortite crystals.

In this study, instead of feldspar, 2-5-10 wt% coal thermal power plant fly ash was used; granite body prepared was fired under industrial rapid firing conditions. Physical properties such as dry strength, fired strength, water absorption, fired shrinkage were examined. At the same time, their effects on microstructure were determined by SEM images, XRD, Edx measurements. In this study, it is aimed to reduce the amount of feldspar by replacing feldspar with 5-10-15% of thermal power plant fly ash in the granite body in the fast firing furnace that makes continuous production and also to obtain positive physical and mechanical properties.

2. EXPERIMENTAL PROCEDURE

Kaolinite, albite, quartz, clay and coal thermal power plant ash were used in the formulation of the granite body. Chemical analyzes of raw materials are shown in Table 1. The mixture was grinded at a density of 1650 g / lt in wet grinding of 2 kg laboratory type cylindrical mills to be 3-4% above 63 microns. Prepared recipes are shown in Table 2. They were dried for 1 day at 110 °C and prepared to be pressed at 5-6% humidity. After that samples in dimensions 7x210x100 mm was pressed 380 kg/cm² in a laboratory-type press. Samples are fired at 1180⁰C in 63 min. industrial continuous kiln. Dwelling time at maximum sintering temperature is 3 min 20 s.

Table 1. Chemical analysis of used raw materials (wt.%)

Raw Materials	SiO ₂	Al ₂ O ₃	Na ₂ O	K ₂ O	CaO	MgO	Fe ₂ O ₃	TiO ₂	SO ₃	L.I.
Clay	54	31.8	0.13	2.03	0.3	0.45	0.67	1.17	-	10.05
Kaolinite	51	34	0.15	1.20	0.20	0.25	0.75	0.25	-	12
Na-Feldspar	68.62	19.53	10.29	0.21	0.99	0.10	0.016	0.042	-	0.14
Quarz	99.35	0.12	0.05	0.06	0.05	0.05	0.06	0.01	-	0.2
Fly ash	18.3	10.02	-	0.15	32.67	1.06	4.6	0.6	18.72	8.05

L.I: Loss on ignition

Tablo 2. Prepared granite body formulations (wt.%)

	1	2	3	4
Kaolinite	25	25	25	25
Albite	30	28	25	20
Quarz	5	5	5	5
Clay	40	40	40	40
Fly Ash	0	2	5	10

The fired strength is made in 3 point gabrielli (italy) test machine. The formula used in the calculation is $\sigma_f = 3xFxL / 2xbxh^2$

where σ_f , F, L, b and h respectively are fracture strength (N/mm²), breaking load (kg), distance between supporting bars (mm), tile width(mm), tile thickness(mm) .

The water absorption test (W) was performed according to the international standard (ASTM C 20) .

$$W(\%) = (W_s - W_d / W_s) \times 100$$

where W_s, W_d respectively wiped surface water saturated weight, dried weight.

The liner shrinkage is measured according to formula

$$L (\%) = (L_1 - L_2 / L_1) \times 100$$

where L₁ and L₂ in order of measured length of green and fired tile samples. Color measurements were measured on a fired body with a Minolta Chroma Meter. L, a, b values indicate lightness, redness and yellowness respectively. The phases in the ceramic body were measured with XRD Pan Analytic Empyron Series 45 Kv, K alpha. Microstructure photographs

were measured in SEM-JEOL JSM-7100 F and Edx in Oxford Instruments x-max quorum with 1 mbar / Pa, 10mA, Au / Pa (80-20%) coating.

RESULTS AND DISCUSSION

3.1. Physical properties

There is no flow feature in 2-5-10 wt.% ash additions in slip with a density of 1650g/lt. Standard slip flows for 40 seconds in the fordcup. This flow characteristics cause problem of decharging of mill. The fired shrinkage of the body decreased in ash amount up to 5% and increased in ash amount up to 10%.

Water absorption value increases with increasing ash amount. It can be seen from the SEM analysis that the reason for this is due to the very fine grain size of ash, wide pore size distribution due to high carbon and volatile material content after sintering and the relatively increased open pores. High fired losses and short firing times are thought to cause this. The reason for the decrease in the water absorption value of Koçkal's study is that the fired loss value is as low as 0.77wt.%. In addition, amount of K_2O and Fe_2O_3 that gives fluxing characteristics, amount of Al_2O_3 and SiO_2 , increase in Al_2O_3 / SiO_2 ratio has an effect on the melting properties. Al_2O_3 / SiO_2 ratio $> 1/10$ show to non-melting or semi-melting behavior (Erciyes) . Ash's ratio Al_2O_3 / SiO_2 is 0.58 that value is high that the reason of refractory properties.

Loss on ignition increases with increasing ash amount. This is due to carbon and other gas impurities in the ash. High fire loss is a negative feature for fast firing bodies (Fortuna, 2000).

The fired strength value decreases with increasing ash amount. The reason for this is thought to be the large pore size distribution within the body that generate from high loss of igniton, insufficient flux properties of ash, also show similar characteristics of chamotte, high Al_2O_3 / SiO_2 ratio that directly effect on melting , reduced mullite content and specially short dwelling time. The sample containing 10% ash showed swelling. Similarly in the study of Koçkal (2012) in place of 20 wt.% fly ash instead of feldspar at 1190 °C bloating was seen in the sample. The increase in pressing pressure increases the strength and makes the gas output difficult. Therefore, high ash content swelling was observed in the study of the Koçkal's study. The reason of increase of fired strength of Koçkal's study is high soaking time of firing schedule, high Fe_2O_3 content that gives fluxing characteristics.

The dry strength value tends to decrease with increasing ash content (Figen et al., 2017), it is seen that dry strength value decreases with increasing amount of ash. This is due to the loss of compressibility due to the very fine ash grain size that cause lamination the body (Koçkal,2012).

Figure 1. Fired shrinkage- ash wt.%

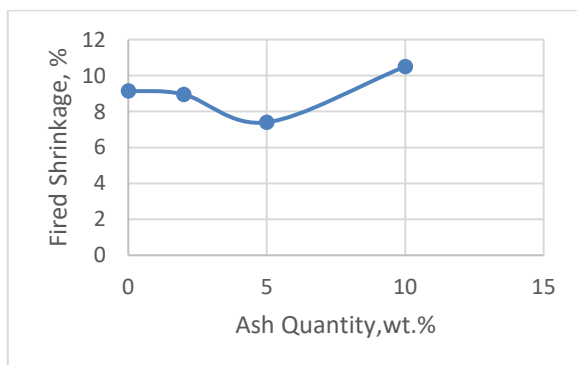


Figure 2. Water absorption-ash wt.%

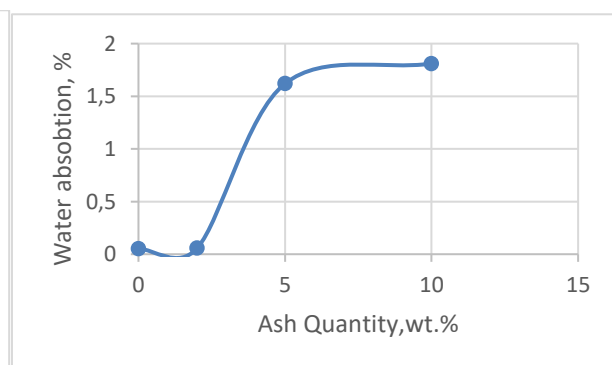


Figure 3. Loss of ignition-ash wt.%

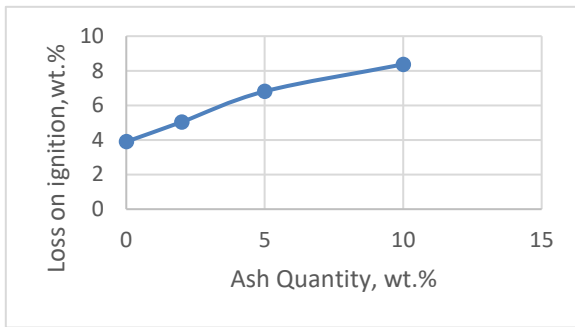


Figure 4. Fired strength-ash wt.%

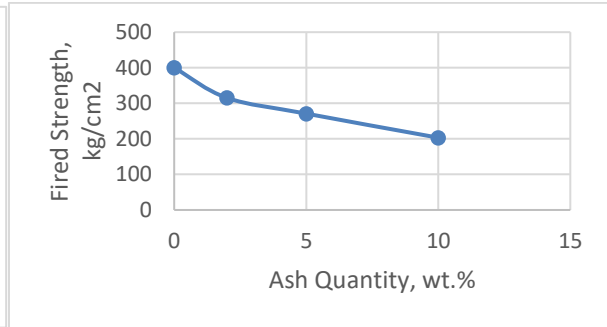


Figure 5. Dry strength-ash.wt.%

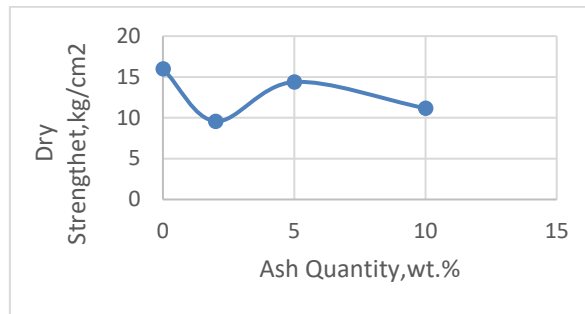


Table 3. Colorimeters values of samples

Sample	L	a	b
1(Std)	47.30	5.36	13.82
2	51.37	3.46	8.38
3	47.75	3.91	15.31
4	47.06	4.13	12.03

Std: Standard

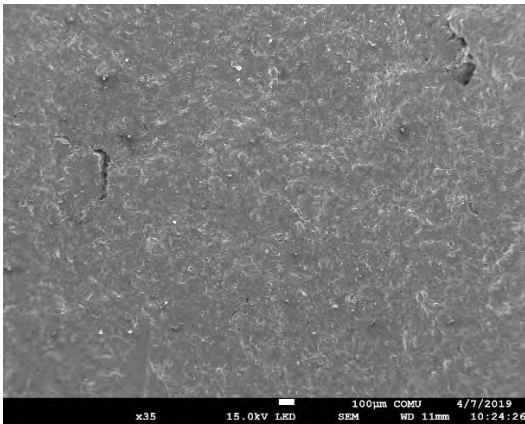
In the ash addition of 2%, the L value increased slightly, which means that lightness increased, a redness and b yellowness values decreased. In further ash additions, the L value is close to standard. The yellowness value b increases up to 5% in the samples containing ash, then decreases. The b value of the body with 2% ash added was significantly reduced.

3.2. Scanning Electron Microscopy Analysis (SEM)

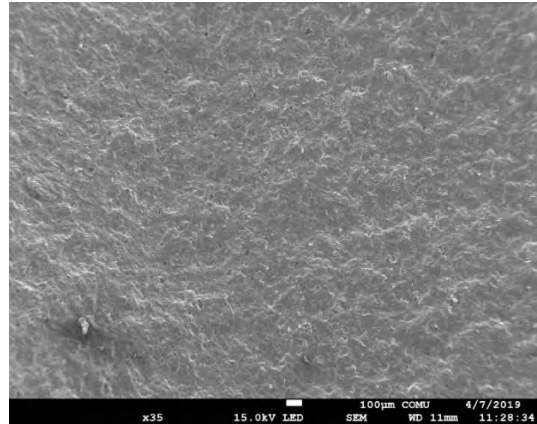
There is a decrease in the number and size of pores in the ash addition structure as seen from SEM analysis. While there are small pores and narrow pore size distribution in the study, Koçkal's study on the subject shows that although it has a low fired loss in ash doped body, larger pores and a larger pore size distribution are observed. This is due to the fact that the melting oxide compounds are high in the study of Koçkal and prevent the release of gas within the body.

Figure 6.1.a,b,c,d,e Sem images of fracture surface of standard body

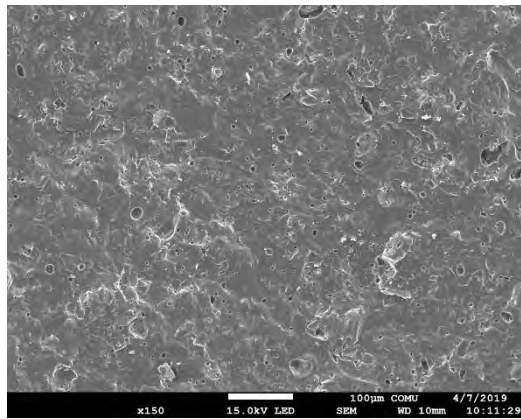
Figure 6.2.a,b,c,d,e Sem images of fracture surface of 2.wt% ash added granite body



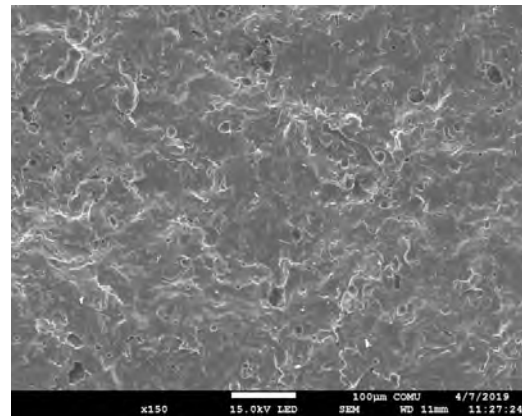
a



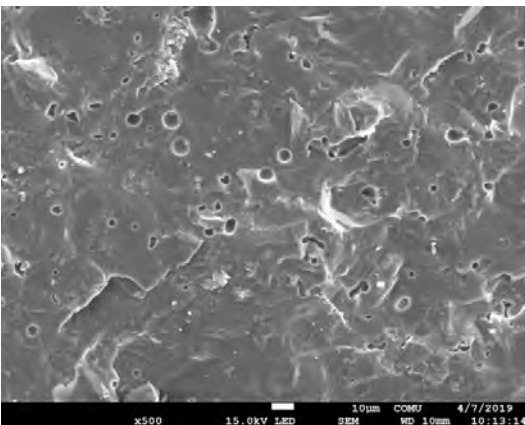
a



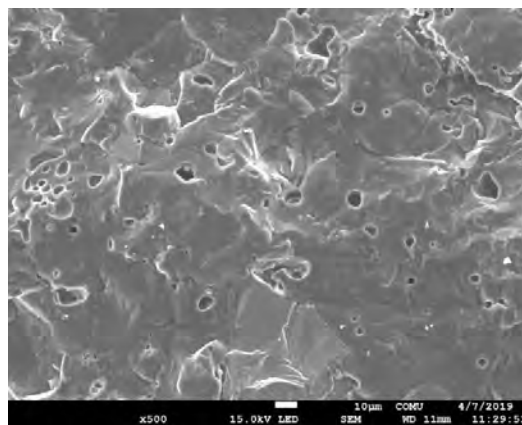
b



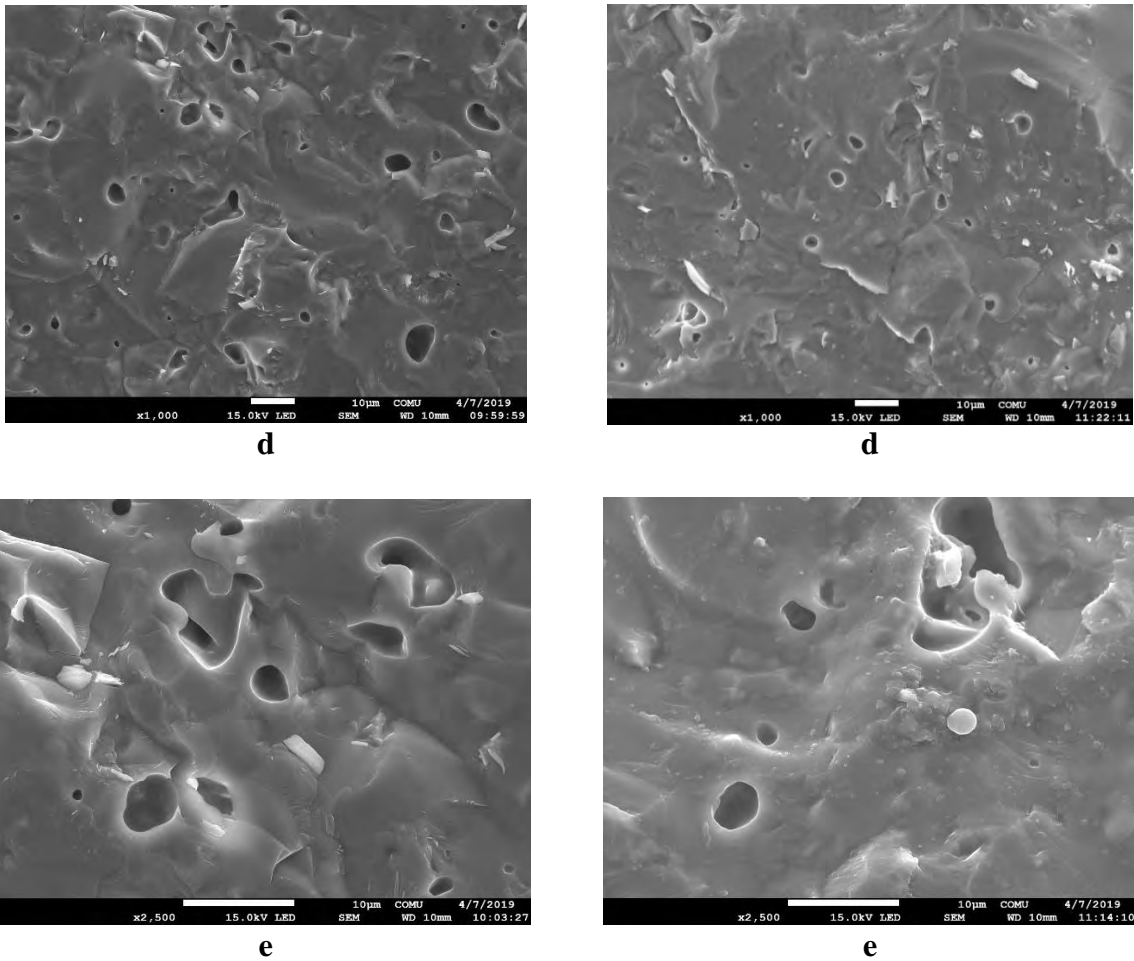
b



c



c



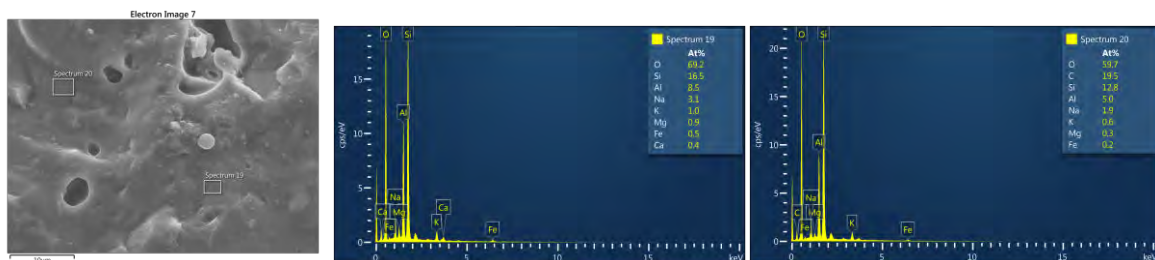
3.3. Energy Dispersive X ray Spectroscopy (Edx) Analysis

In the edx analysis of the ash-containing body, components such as C and Ca are seen in the body. At the same time, it has been observed that carbon-containing impurities are in particulate form due to lack of good mixing and grinding. The varying amounts of elements at different magnifications indicate that there is no homogeneous mixture.

Figure 7. Edx analysis of standard granite body

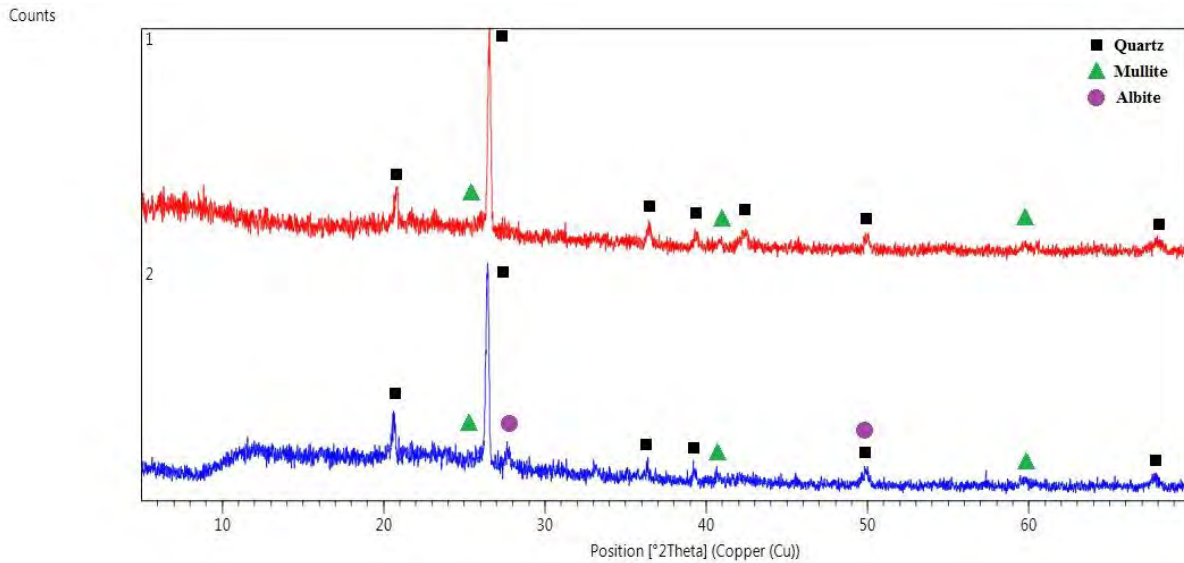


Figure 8. Edx analysis of 2wt.% ash added granite body



3.4. X-ray Diffraction Pattern (XRD) Analysis

Figure 9. XRD analyzes of standard (1) and 2 wt.% ash added granite body (2)



While the standard body (1) contained 77.2% quartz and 22.8% mullite, the amount of with 2% ash added (2) was 41.5% quartz, mullite 12.2% and albite 46.3%. CaO content changed the activity, triggered quartz transformation (Richerson, 1992); thereby increasing quartz solubility. This changing chemical activity reduced mullitization reactions and triggered albite formation. Luo et al.(2017) study at 1150 °C, it was observed that albite was formed in addition to mullite and quartz in ash-tempered ceramic structure. In the study of Koçkal (2012), quartz, cristobalite, hematite and plagioclases (albite, anorthite) were observed at 1190 °C in ceramic with thermal power plant ash. Viscosity and chemical reactivity of the liquid phase affect the mullitization reactions.

4. CONCLUSION

2% thermal power plant ash was found to be usable in granite structure. Acceptable physical properties were obtained for the standard body. L, lightness value increased slightly in 2% sample and red and blue value decreased. When the microstructure was examined, quartz and mullite were 77.2% and 22.8% respectively in the standard structure, whereas quartz and mullite amount in the 2% ash doped sample was 41.5% and 12.2%, respectively. Albite was observed in 46.3% of the sample with the same ash addition, albite formation reactions were triggered. This shows that chemical reactivity of the liquid phase change significantly. Chemical analysis of ash, SiO₂/ Al₂O₃ ratio, amount of melting oxide such as Na₂O and Fe₂O₃ and gas output quantity affect ash properties, usage area and amount of ash.

REFERENCES

- AMIN, Sh.K., ABDEL HAMID, E.M., EL-SHERBINY, S.A., SIBAK, H.A., ABADIR, M.F.,2018, The use of sewage sludge in the production of ceramic floor tiles, Housing a Building National Research Center (14) 309-315
- ASTM, C 20, Standard test methods for apparent porosity, water absorption, apparent specific gravity and bulk density of burned refractory brick and shapes by boiling water, Annual Book of ASTM Standards, 2000
- DANA, K., DAS, S., DAS, S.K., 2004, Effect of substitution of fly ash for quartz in triaxial kaolin- quartz-feldspar system, Journal of the European Ceramic Society (24) 3169-3175
- ELMAS, S., 2019, Using Fired Wall Tiles Scraps in Floor Tile Body, Journal of scientific perspectives Vol 3 No 2
- ERCIYES, İ.T., Karo Seramik Üretim Teknolojisi, Teknik Yayınlar Serisi II, ÇİTOSAN
- FIGEN, A. K., ÖZÇAY, Ü., PIŞKIN, S.,2017, Manufacturing and Characterization of Roof Tiles a Mixture of Tile Waste and Coal Fly Ash, Suleyman Demirel University Journal of Natural and Applied Sciences Volume 21, Issue 1, 224-229
- Fortuna, Domenica,2000, Sanitaryware, Italy
- JI, R., ZHANG, Z., YAN CHEN, ZHU, M., LI, Z., 2016, Preparation of novel ceramic tiles with high Al₂O₃ content derived from coal fly ash, Construction and Building Materials (114) 888-895
- KOCKAL, N.U ,2012, Utilization of different types of coal fly ash in the production of ceramic tiles, Ceramica y Vidrio Vol 51, 5, 297-304, Spain
- LUO, Y., ZHENG, S, MA SHUHUA, LIU CHUNLI, WANG, X., 2017,Ceramic tiles derived from coal fly ash: preparation and mechanical characterization, Ceramics International (43) 11953-11966
- LUZ, A. P., RIBEIRO, S., 2007, Use of glass waste as a raw material in porcelain stoneware tile mixtures, Ceramic International (33) 761-765
- OZDEMIR, I., YILMAZ, S., 2007, Processing of unglazed ceramic tiles from blast furnace slag, Journal of Materials Processing Technology (183) 13-17
- OZTURK, Z. B., GULTEKIN, E. R., 2015, Preparation of ceramic wall tiling derived from blast furnace slag, Ceramic International (41) 12020-12026
- RICHERSON, D. W., Modern Ceramic Engineering , Properties,Processing and Use in Design 2.Edition, Marcel Dekker Inc.,1992, New York
- TRNIK, A., STUBNA, I., SOKOLAR, R., MEDVED, I., 2013, Use of fly ash in ceramic tiles: elastic properties during firing, Journal of the Ceramic Society of Japan 121 (11) 925-929
- Türkiye'deki Uçucu Küllerin Sınıflandırılması ve Özellikleri,2009, Türkiye Çimento Müstehsilleri Birliği, Ankara,Turkiye
- ZONG, Y., ZHANG, X., MUKIZA, E., XU XIAOXIONG, LI, F., 2018, Effect of Fly Ash on the Properties of Ceramics Prepared from Steel Slag , Applied Sciences 8, 1187-1197

THE EFFECTS OF POTASSIUM APPLICATIONS ON DROUGHT STRESS IN SUGAR BEET: PART I. SUGAR BEET QUALITY COMPONENTS

Gizem AKSU* & Hamit ALTAY**

* Canakkale Onsekiz Mart University, Faculty of Agriculture,
Department of Soil Science and Plant Nutrition, TURKEY,
e-mail: gizemaksu@comu.edu.tr
ORCID: <https://orcid.org/0000-0003-2014-9454>

** Canakkale Onsekiz Mart University, Faculty of Agriculture,
Department of Soil Science and Plant Nutrition, TURKEY,
e-mail: haltay@comu.edu.tr
ORCID: <https://orcid.org/0000-0003-3872-500X>

Received: 5 December 2019, Accepted: 25 March 2020

ABSTRACT

This is the first in a series of papers describing the effects of potassium applications on drought stress in sugar beet. Drought stress is the stress to which there is the most exposure in agricultural areas. In this research, the effect of potassium applications under drought stress on some quality parameters of sugar beet, which is a strategic plant, was investigated. In the experiment, irrigation levels were kept at 33%, 66% and 100% of field capacity. Different doses (10-20-40-80 mg kg⁻¹) of potassium were applied to the plants. The plants were grown in the growth chamber under controlled conditions (day/night 16/8 hours, 25/15 °C, 60-70% humidity). A comparison of the plants irrigated at the level of 100% of the field capacity and stressed plants showed that the root sugar content decreased by 53.18% and 65.1%, and shoot sugar content by 20.8% and 17.8% respectively at 66% and 33% irrigation levels. Root white sugar content (58.61 mg g⁻¹) was obtained at the dose of 10 mg kg⁻¹ potassium level, while the lowest (32.61 mg g⁻¹) was obtained at the dose of 80 mg kg⁻¹ potassium level. Shoot protein content has increased significantly with an increasing level of potassium under drought (33% and 66%) condition. The root α -amino nitrogen content decreased under drought stress with increasing potassium concentrations while it increased in non-stressed plants. According to the results obtained from the experiment, the potassium applied to the plants under drought stress led to the increase of the root sugar, root white sugar content and shoot protein content the reduction of root α -amino nitrogen content. Therefore, it can be said that potassium may play a critical role in reducing the negative effect of drought stress in sugar beet.

Key Words: Drought, Irrigation, Potassium, Sugar Beet.

1. INTRODUCTION

Stress is defined as factors that preventing plant growth. According to Levitt, stress factors are divided into biotic and abiotic (Levitt, 1980). In the world, only 10% of the areas available for agriculture are not faced with any environmental stress factors (Dudal 1976). The remaining 90% of the area is under the influence of 26% drought stress, 20% salt stress, 15% cold and frost stress and 29% other stresses (Blum 1986; Ashraf 1994). Global warming is caused by climate changes that may increase drought stress. Drought is one of the main abiotic factors that limit plant growth and crop productivity (Farooq et al., 2009). Approximately 45% of the world's agricultural land is constantly exposed to drought stress (Asraf and Foolad 2007). Drought stress negatively affects of plant metabolism and plant undergoes significant changes under drought stress. These can result in plants being smaller than the normal size, early maturation, a decrease or increase in root length, an increase in root-shoot ratio, a decrease in the leaf area and weight and leaf curl (Karamanos and Papatheohari 1999; Terzi and Kadioğlu 2006; Cattivelli et al. 2008, Jaleel et al. 2009). It has also been determined that drought stress leads to a decrease in the amount of photosynthetic pigment in plant leaves (Richardson et al. 2004). Plants increased synthesis of osmoprotectants to cope with drought stress (Fayez and Bazaid 2014). When plants are exposed to stress, they take various ions from the soil solution or synthesize some organic compounds, thereby reducing their osmotic potential (Ashraf 1994; Yordanov et al. 2003). Considering the basic function of potassium, which provides water balance, fertilizers with sufficient amount of potassium can give high yield in stress conditions (Kemmler and Krauss 1989). Plant needs higher amounts potassium for photosynthesis and assimilates transport (Wang et al. 2015). Sufficient levels of potassium increase drought resistance of plant (Eakes et al. 1991). The aim of this research is to determine the effect of potassium applications on some quality components of sugar beet, which is a strategic plant, under drought stress and to try to clarify the relationship between drought stress and potassium.

2. MATERIAL METHOD

2.1 Plant Growth

In this study, washed sand, with a pH of 8.2 and electrical conductivity of $75 \mu\text{M cm}^{-1}$, was used. The sand was filled into 25X50 cm plastic sapling production bags. Resistive soil moisture sensors were put inside the sand to control the moisture level. Moisture sensors were calibrated with a device designed using an Arduino developer card, and irrigation was carried out according to the data received from that device (Kızıllı et al. 2018). Irrigation levels were kept at 33%, 66% and 100% of field capacity. Serenad varieties of sugar beet (*Beta vulgaris* L.) plants were grown in the climate room under controlled conditions (day/night 16/8 hours, 25/15 °C, 60-70% humidity). Different doses (10-20-40-80 mg kg⁻¹) of potassium were applied to the plants with a potassium phosphate source. Plants were grown considering the 1: 0.8: 1.2, N: P: K ratio (Adiloglu and Guler 2002), with 3 replicates for 4 months. Plants were harvested after sampling the leaves for relative water content and membrane damage.

2.2 Protein content ($\mu\text{g g}^{-1}$)

Samples of 500 mg were taken from plant leaves and ground in liquid nitrogen and added 1.5 ml of phosphorus buffer (pH 7). The samples were centrifuged at 4°C for 20 minutes at 14000 rpm. A sample of 5 μl , 450 μl distilled water and 5 ml Bradford reagent were added to the tubes and incubated for 15 minutes at room temperature. The samples were read in a spectrophotometer (UV/Vis) at 595 nm wavelength. Protein standards were prepared with bovine serum albumin between 0-100 $\mu\text{g ml}^{-1}$ (Bradford, 1976).

2.3 Sugar content (mg g⁻¹)

The shoot and root samples were dried in an oven for 48 hours at 65 °C and ground. Samples of 50 mg were taken and 2 ml of 70% ethyl alcohol was added. The mixture was incubated in a hot water bath at 80°C for 60 minutes. The samples were centrifuged for 20 minutes at 3500 rpm. Supernatant of 1000 µl, 300 µL 5% phenol and 2000 µl concentrated sulfuric acid were put into the tubes and the reaction mixture was vortexed. The samples were read in a spectrophotometer (UV/Vis) at 488 nm wavelength. Sugar content was calculated with standard graphic prepared with sucrose (Dubois, 1956).

2.4 α-amino nitrogen content (mg kg⁻¹)

Amino-nitrogen content was determined with a spectrophotometer (UV/Vis) at 623 nm wavelength using the copper method (International Commission for Uniform Methods of Sugar Analysis, 2007).

2.5 White sugar content (mg g⁻¹)

White sugar content was calculated by using the data of sugar content of roots, root α-amino nitrogen content, root Na and K content by the following equation (Reinefeld et al. 1974).

$$\text{White sugar content} = \text{Sugar content} - (0.343(\text{Na} + \text{K}) + (0.094 * \alpha\text{-amino nitrogen}) + 0.29)$$

2.6 Statistical analysis

Analysis of variance (ANOVA) was performed using the general linear model (PROC GLM) procedure of R program. The variance analysis was done based on the following model:

$$Y_{ijk} = \mu + G_i + S_j + (GS)_{ij} + M_k + e_{ijk}$$

Where:

Y_{ijk} : observed value

μ : grand mean

G_i : effect of irrigation i (i=1, 2, 3)

S_j : effect of potassium j (j=1, 2, 3, 4)

$(GS)_{ij}$: effect of irrigation x effect of potassium

M_k : effect of replication k (k = 1, 2, 3)

e_{ijk} : random error term

Variance analysis (ANOVA) was performed by using the statistical package program using the GLM procedure. Differences between applications were determined by the Tukey multiple comparison test (P <0.05).

3. RESULTS

According to the results of variance analysis, the effect of irrigation x potassium interaction shoot sugar content, root sugar content, root white sugar content was statistically significant (P ≤ 0.01). In addition, it was determined that the effect of irrigation and potassium applications on shoot sugar content, root sugar content, root white sugar content were statistically significant (Table 1).

Table 1. Mean squares for shoot sugar content, root sugar content, root white sugar content

Source of Variation	Df	Shoot sugar content	Root sugar content	Root white sugar content
Irrigation	2	8061.41**	141.322**	8030.82**
Potassium (K)	3	1494.27**	2.551*	1486.15**
Irrigation * K	6	555.52**	18.465**	555.87**
Error	22	1.49	0.637	1.49

*, ** Indicates significant difference at $P \leq 0.05$, $P \leq 0.01$ respectively. Df: Degrees of freedom.

Shoot sugar content increased with the increase of irrigation levels to 26.34, 25.38 and 32.04 mg g⁻¹ respectively. Shoot sugar content increased with potassium applications up until the 80 mg kg⁻¹ potassium application (Table 2). The lowest shoot sugar content (5.29 mg g⁻¹) was obtained at the 66% irrigation level and 80 mg kg⁻¹ potassium application, the highest shoot sugar content (8.94 mg g⁻¹) at the 100% irrigation level and 80 mg kg⁻¹ potassium application (Table 2). When the root sugar content is considered, it is observed that root sugar content increases with increasing irrigation levels and increasing potassium applications. The lowest root sugar content (22.04 mg g⁻¹) was obtained at the 33% irrigation level and 20 mg kg⁻¹ potassium application, the highest root sugar content (99.945 mg g⁻¹) at the 100% irrigation level and 80 mg kg⁻¹ potassium application (Table 2).

Table 2. Mean values of shoot sugar content, root sugar content

K (mg kg ⁻¹)	Irrigation (Field Capacity)				Irrigation (Field Capacity)			
	33%	66%	100%	Mean	33%	66%	100%	Mean
	Shoot sugar content (mg g ⁻¹)				Root sugar content (mg g ⁻¹)			
10	28.43 cde	25.02fg	30.50 bc	27.98 AB	25.79 fg	23.91 gh	47.99 d	32.56 D
20	25.82 ef	29.16 cd	30.57 bc	28.51 A	22.04 h	29.28 f	57.12 c	36.15 C
40	26.23 def	24.97 f	32.84 ab	28.01 AB	33.20 e	33.31 e	94.54 b	53.68 B
80	24.90 f	22.37 g	34.25 a	27.18 B	23.36 gh	53.54 c	99.45 a	58.78 A
Mean	26.34 B	25.38 B	32.04 A		26.10 C	35.01 B	74.78 A	

†The differences between the interaction potassium and Irrigation means having different lower case letters in a column are statistically significant at 0.05 alpha level. ††The differences between the potassium means having different capital letters in a column are statistically significant at 0.05 alpha level. The differences between the irrigation means having different capital letters in a line are statistically significant at 0.05 alpha level.

White sugar content of roots is given in Table 3. White sugar content of roots increased with the increase of irrigation levels and potassium applications. The lowest root white sugar content (21.98 mg g⁻¹) was obtained at 33% irrigation level and 20 mg kg⁻¹ potassium application, the highest root white sugar content (99.24 mg g⁻¹) at 100% irrigation and 80 mg kg⁻¹ potassium application.

Table 3. Mean values of root white sugar content

K (mg kg ⁻¹)	Irrigation (Field Capacity)			Mean
	33%	66%	100%	
	Root white sugar content (mg g⁻¹)			
10	25.73fg	23.84 gh	47.85 d	32.47 D
20	21.98 h	29.20 f	56.95 c	36.05 C
40	33.10 e	33.20 e	94.35 b	53.55 B
80	23.22gh	53.38c	99.24 a	58.61 A
Mean	26.01 C	34.90 B	74.60 A	

†The differences between the interaction potassium and Irrigation means having different lower case letters in a column are statistically significant at 0.05 alpha level. ††The differences between the potassium means having different capital letters in a column are statistically significant at 0.05 alpha level. The differences between the irrigation means having different capital letters in a line are statistically significant at 0.05 alpha level.

According to the results of variance analysis, the effect of irrigation x potassium interaction shoot protein content and root α -amino nitrogen content was statistically significant ($P \leq 0.01$). In addition, it was determined that the effect of irrigation and potassium applications on shoot protein content and root α -amino nitrogen content were statistically significant (Table 4).

Table 4. Mean squares for shoot protein content, root α -amino nitrogen content

Source of Variation	Df	Shoot protein content	Root α -amino nitrogen content
Irrigation	2	119039**	82.1126**
Potassium (K)	3	32097**	72.6078**
Irrigation * K	6	20262**	94.1099**
Error	22	95	0.0261

*, ** Indicates significant difference at $P \leq 0.05$, $P \leq 0.01$ respectively. Df: Degrees of freedom.

Shoot protein content showed an irregular change and decreased with irrigation levels to 688, 473 and 610 $\mu\text{g g}^{-1}$ respectively. Protein content of shoots increased with the increase of potassium applications. The lowest shoot protein content (433 $\mu\text{g g}^{-1}$) was obtained at the 66% irrigation level and 10 mg kg⁻¹ potassium application, the highest shoot protein content (900 $\mu\text{g g}^{-1}$) at the 33% irrigation level and 80 mg kg⁻¹ potassium application (Table 5). Root α -amino nitrogen content increases with increasing irrigation levels to 14.11, 16.13 and 19.30 mg kg⁻¹ respectively. Root α -amino nitrogen content decreased with potassium applications up until the 80 mg kg⁻¹ potassium application. The lowest Root α -amino nitrogen content (11.29 mg kg⁻¹) was obtained at the 33% irrigation level and 20 mg kg⁻¹ potassium application, the highest root α -amino nitrogen content (29.37 mg kg⁻¹) at the 100% irrigation level and 80 mg kg⁻¹ potassium application (Table 5).

Table 5. Mean values of shoot protein content, root α -amino nitrogen content

K (mg kg ⁻¹)	Irrigation (Field Capacity)				Irrigation (Field Capacity)			
	33%	66%	100%	Mean	33%	66%	100%	Mean
	Shoot protein content ($\mu\text{g g}^{-1}$)				Root α -amino nitrogen content (mg kg ⁻¹)			
10	552 c	433 g	588 d	524 C	17.22 d	24.51 b	14.87 e	18.86 A
20	596 d	483f	645 c	574 B	11.29 i	14.47 ef	14.23 f	13.33 C
40	707 b	453 fg	603 d	588 B	13.69 g	12.28 h	18.71 c	14.90 B
80	900 a	525e	603 d	676 A	14.22 f	13.26 g	29.37 a	18.95 A
Mean	688 A	473C	610 B		14.11 C	16.13 B	19.30 A	

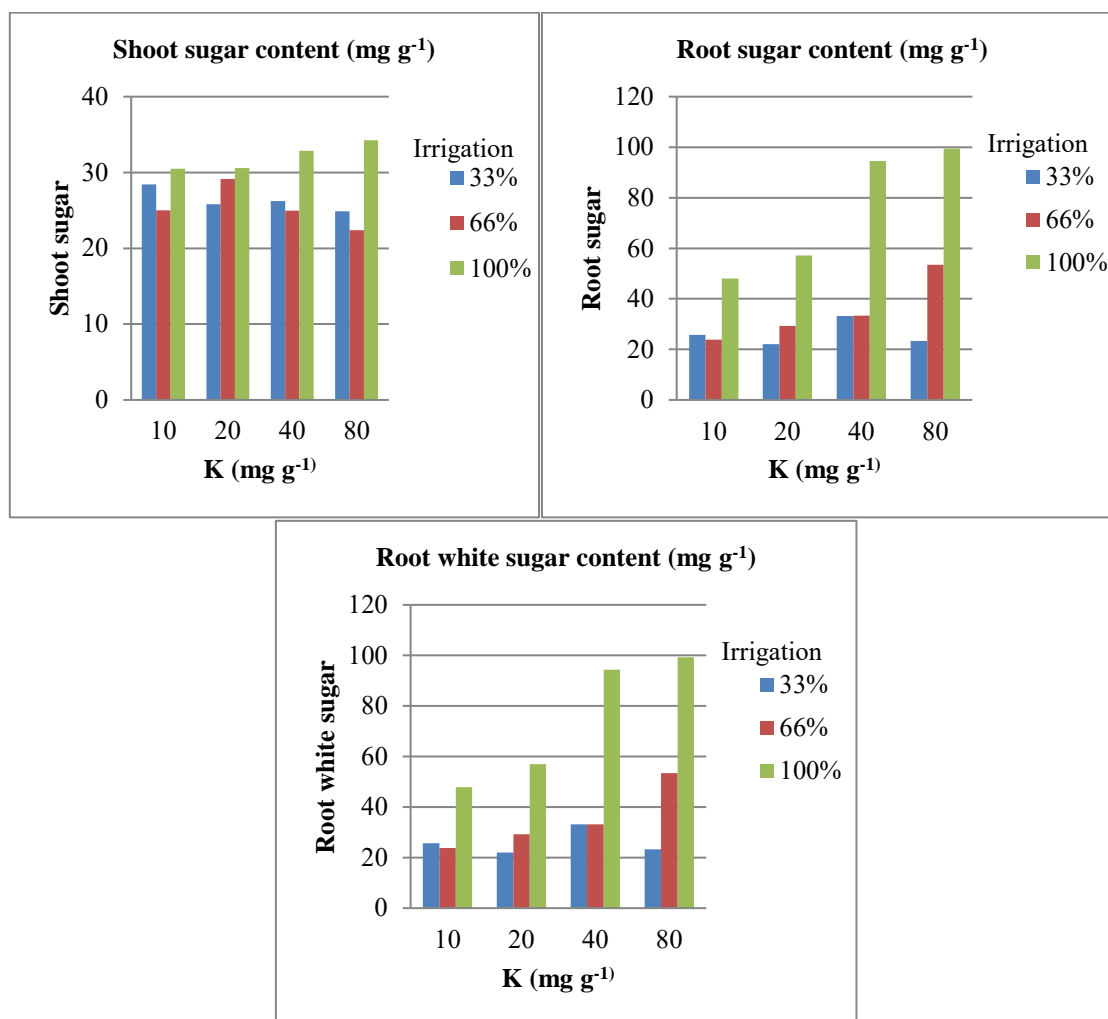
†The differences between the interaction potassium and Irrigation means having different lower case letters in a column are statistically significant at 0.05 alpha level. ††The differences between the potassium means having different capital letters in a column are statistically significant at 0.05 alpha level. The differences between the irrigation means having different capital letters in a line are statistically significant at 0.05 alpha level.

4. DISCUSSION

The accumulation of soluble sugar in plants is a response to drought stress (Zhang et al. 2009). Under drought, sugar beet sucrose storage has been found to be decreased as a result of the accumulation of ions and solutes (Hoffmann, 2010). According to the results, shoot sugar content has increased with increasing irrigation levels (Figure 1). Shoot sugar content is lower in stressed plants than plants grown under normal conditions. In the same way root sugar content increased with irrigation levels. A comparison of the plants irrigated at the level of 100% of the field capacity and stressed plants showed that the root sugar content decreased by 53.18% and 65.1%, and shoot sugar content by 20.8% and 17.8% respectively at 66% and 33% irrigation levels (Table 2). Our results are not in parallel with Shehata et al. (2000) study they found that growth and yield of sugar beet shoot were affected by drought more than the roots.

Many studies show that sugar beet reduced growth and increased sugar concentration in roots for a response to water shortage (Ucan and Gencoglan 2004, Mahmouda et al., 2018, Mansuri et al., 2018). In contrast to these studies according to our results root sugar content showed an important increment in response to the increasing levels of irrigation (Figure 1). In this study, the highest root sugar content (74.78 mg g⁻¹) was obtained at the 100% irrigation level, while the lowest (26.1 mg g⁻¹) was obtained at the 33% irrigation level. According to other researcher sugar content increased with irrigation levels (Yonts, 2011, Ghamarnia et al. 2012) and our results are in parallel with these studies.

Figure 1. Shoot sugar content, root sugar content and root white sugar content (mg g^{-1}) changes



Potassium raises synthesis of carbohydrates therefore recoverable sugar content of beet was increased by increasing in potassium concentration (Milford et al 2000; Attia 2004). Potassium has important role in translocation of assimilates to sink so if sugar beet plants cannot reach sufficient potassium, translocation of photosynthates from leaves to roots reduced (Hermans et al., 2006). When Table 2 and Figure 1 are examined, it is seen that root sugar content increases with increasing potassium application which is in parallel with previous studies. According to McDonnell et al. (1966) stated that the potassium fertilizers increased root sugar content of sugar beet and on the other hand according to many researchers, the application of potassium did not affect sugar content (Bee et al., 1997; Shalaby et al., 2002 Turhan and Piskin, 2005).

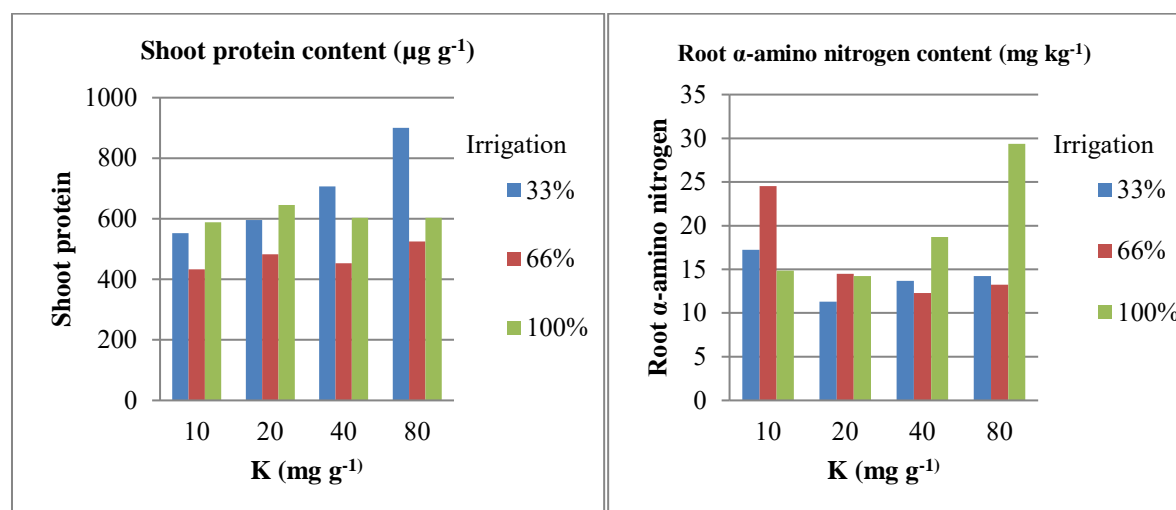
When results are examined in terms of the interaction between irrigation levels and potassium, although there is a decrease with the dose of 20 mg kg^{-1} at the 33% irrigation level, root sugar content increased in parallel with the increasing potassium doses while it decreased at 80 mg kg^{-1} . The root sugar content increased parallel to the increasing potassium doses at the 66% irrigation level. According to Mubarak et al., (2016) increase in the level of potassium application at water sufficient level significantly increased plant growth, beet yield and industrial beet sugar content. The response of potassium under drought condition was also similar. Potassium could be used improve beet sugar content both under water-deficient as well as water-sufficient conditions. The most economically significant indicator in the sugar beet

production is white sugar content (Dadkhah 2005). White sugar content increased in drought condition about 58.86% in compare to normal condition (Habibi, 2011).

Our results are in parallel with Masri et al., (2015) study their results showed significant increase in root yield and white sugar yield by increasing irrigation water requirement from 50% up to 75 and 100%. A comparison of the plants irrigated at the level of 100% of the field capacity and stressed plants showed that the white root sugar content decreased by 53.21% and 65.13% respectively at 66% and 33% irrigation levels (Table 3). Topak et al. (2011) reported that root and white sugar yields of sugar beet significantly decreased with drought. In contrast to this study according to our results root white sugar content showed an important increment in response to the increasing levels of irrigation (Figure 1).

Increasing the rate of potassium application resulted in significant increase white sugar yields. (Ibrahim, 2002) potassium application increment improved sugar beet quality more than its productive quality. When Table 3 and Figure 1 are examined, it is seen that root white sugar content increases with increasing potassium application which is in parallel with previous studies. In this study, the highest root white sugar content (58.61 mg g^{-1}) was obtained at the dose of 10 mg kg^{-1} potassium level, while the lowest (32.61 mg g^{-1}) was obtained at the dose of 80 mg kg^{-1} potassium level.

Figure 2. Shoot protein content ($\mu\text{g g}^{-1}$) and root α -amino nitrogen content (mg kg^{-1}) changes



When results are examined in terms of the interaction between irrigation levels and potassium, although there is a decrease with the dose of 20 mg kg^{-1} at the 33% irrigation level, root white sugar content increased in parallel with the increasing potassium doses while it decreased at 80 mg kg^{-1} .

The root white sugar content increased parallel to the increasing potassium doses at the 66% irrigation level. El-Kammah (1995) stated that the interaction between drought periods and potassium on white sugar was significant our results parallel with these studies.

According to the results, shoot protein content has decreased with increasing irrigation levels (Table 5). Shoot protein content is lower in unstressed plants than plants grown under stress conditions. In this study, the highest shoot protein content ($688 \mu\text{g g}^{-1}$) was obtained at the 33% irrigation level, while the lowest ($473 \mu\text{g g}^{-1}$) was obtained at the 66% irrigation level.

Potassium has significant effect on protein synthesis, enzyme activation, water-relation and photosynthesis in plants (Marschner 1995). Potassium keeps normal balance between carbohydrates and proteins (Moustafa and Darwish, 2001; Monreal et al., 2007). In this study, the highest shoot protein content ($676 \mu\text{g g}^{-1}$) was obtained at the dose of 80 mg kg^{-1} potassium

level, while the lowest ($524 \mu\text{g g}^{-1}$) was obtained at the dose of 10 mg kg^{-1} potassium level (Figure 2).

When Table 5 is examined, it is seen that shoot protein content has increased significantly with a increasing level of potassium under drought (33% and 66%) condition. Similar results were obtained in previous studies they have reported a positive correlation between potassium content and amino acids (Zahoor et al., 2017). According to results, potassium plays a significant role in shoot protein content under drought stress.

The root α -amino nitrogen content decreased parallel to the increasing potassium doses while it increased at 80 mg kg^{-1} . Similar to our results Ferweez and Abo El Wafa (2004) stated that root α -amino nitrogen content were increased with increasing potassium. According to many researchers, the application of potassium did not affect root α -amino nitrogen content (Bee et al., 1997; Turhan and Pişkin, 2005).

When results are examined in terms of the interaction between irrigation levels and potassium, the root α -amino nitrogen content decreased under drought stress with increasing potassium concentrations while it increased in non-stressed plants.

5. CONCLUSION

According to the results of variance analysis, the effect of irrigation x potassium interaction on the shoot sugar content, root sugar content, root white sugar content, shoot protein content and root α -amino nitrogen content was found to be statistically significant.

Root sugar content and root white sugar content increased with potassium applications under drought conditions. The root α -amino nitrogen content under drought stress decreased with increasing potassium concentrations while it increased in non-stressed plants. It is suggested that there is a great potential of potassium use in sugar beet to produce quality beet for economical industrial sugar production. The shoot protein content increased with the increase in potassium applications under drought condition. This demonstrates the role of potassium in reducing the damage of drought-dependent protein synthesis. Thus, it can be said that potassium may play a critical role in reducing the negative effects of drought stress in sugar beet. Therefore, it is thought that keeping the K nutrition at a sufficient level for the plants grown in the regions where irrigation may be a problem can be beneficial in reducing the damage of drought stress.

Acknowledgments

This research is a part of the first author's Ph.D. thesis.

REFERENCES

- ADILOGLU, A. and GULER, M., 2002, Tekirdag-hayrabolu yöresinde yetiştirilen seker pancarının (*Beta Vulgaris L.*) beslenme durumunun belirlenmesi. S. Ü. Ziraat Fakültesi Dergisi, 16 (29):26–30.
- ASHRAF, M., 1994, Breeding for salinity tolerance in plants, Crit. Rev. Plant Sci., 13:17–42.
- ATTIA, K.K., 2004, Effect of saline irrigation water and foliar application with K, Zn and B on yield and quality of some sugar beet cultivars grown on a sandy loam calcareous soil, Workshop on "Agricultural Development in the Arab Nation, Obstacles and Solutions" January, 20-22, Assiut, Egypt.
- BEE, P.M., JARVIS, P.J. and ARMSTRONG, M.J., 1997, The effect of potassium and sodium fertiliser on sugar beet yield and quality, Proceedings of the 60th International Institute for Beet Research Congress, July, Cambridge (UK).
- BLUM, A., 1986, Breeding crop varieties for stress environments, Crit. Rev. Plant Sci., 2: 199–23.
- BRADFORD M.M., 1976. A rapid and sensitive method for the quantification of microgram quantities of protein utilizing the principle of protein dye binding, Analytical Biochemistry, 72, 248-254.
- CATTIVELLI, L., RIZZA F., BADECK F.W., MAZZUCOTELLI E., MASTRANGELO, FRANCA, A.M.E., MARE, C., TONDELLI A. and STANCA. A.M., 2008, Drought tolerance improvement in crop plants: An integrated view from breeding to genomics, Field. Crop. Res., 105:1–14.
- DADKHAH, A.R. 2005, Response of root yield and quality of sugar beet (*Beta vulgaris L.*) to salt stress, Iran Agricultural Research, 23–24:33–42.
- DUBOIS, M., GILLES, K.A., HAMILTON, J.K., REBERS, P.A., SMITH, F., 1956, Colorimetric method for determination of sugars and related substances, Anal. Chem., 28, 350– 356.
- DUDAL, R., 1976. Inventory of major soils of the world with special reference to mineral stress, Cornell Univ. Agric. Exp. Stn, Ithaca.
- EAKES, D.J., WRIGHT, R.D. and SEILER, R., 1991, Potassium nutrition and moisture stress tolerance of *Salvia*, HortScience, 26:422.
- EL-KAMMAH, M.A., 1995, Quantity of sugar beet biomass as affected by interrelationships of water irrigation regimes and fertilization, J. Agric. Sci., Mansoura University, 20: 5249–5263.
- FAROOQ, M., WAHID, A., KOBAYASHI, N., FUJITA, D. and BASRA S.M.A., 2009, Plant drought stress: Effects, mechanisms and management, Agron Sustain. Dev., 29:185–212.
- FAYEZ, A.K. and BAZAID A.S., 2014, Improving drought and salinity tolerance in barley by application of salicylic acid and potassium nitrate, Journal of the Saudi Society of Agricultural Sciences, 13:45–55.
- FERWEEZ, H. and ABOELWAF A.M., 2004, Enhancing the productivity, quality and profitability of sugar beet using optimal levels and addition time of potassium fertilizer under middle Egypt conditions, Assuit J. Agric. Sci., 35(3), 108-127.
- GHAMARNIA, H., ARJI, I. SEPEHRI, S. NOROZPOUR, S. and KHODAEI. E., 2012, Evaluation and comparison of drip and conventional irrigation methods on sugar beets in a semiarid region, Journal of Irrigation and Drainage Engineering, 138:90-97.

- HABIBI, D., 2011, Evaluation of antioxidant enzymes activity in sugar beet genotypes under drought stress, Magnt Research Report, Vol.2 (3):225-238.
- HERMANS, C., HAMMOND, J.P., WHITE, P.J. and VERBRUGGEN, N., 2006, How to plants respond to nutrient shortage by biomass allocation? Trends in Plant Science, 11, 610–617.
- HOFFMANN, C.M., 2010, Sucrose accumulation in sugar beet under drought stress, Journal of Agronomy and Crop Science, 196: 243–252.
- IBRAHIM, B.S. 2006, Sugar beet types and some microelements in relation to yield and quality. MSc thesis, Faculty of Agriculture, Benha University Banha, Egypt.
- INTERNATIONAL Commission on Uniform Methods of Sugar Analysis. 2007. Method GS6-5, Determination of α -amino nitrogen by the copper method ('Blue number'). Verlag Dr. Albert Bartens, KG, Berlin.
- JALEEL, C.A., MANIVANNAN, P., WAHID, A., FAROOQ, M., AL-JUBURI, H.J., SOMASUNDARAM R. and VAM, R.P., 2009, Drought stress in plants a review on morphological characteristics and pigments composition, Int. J. Agric. Biol., 11:100-105.
- KARAMANOS, A.J. and PAPTATHEOHARI. A.Y., 1999, Assessment of drought resistance of crop genotypes by means of the water potential index, Crop.Sci., 39:1792–1797.
- KEMMLER, G. and KRAUSS. A., 1989, Potassium and stress tolerance, Proceedings of the Workshop on The Role of Potassium in Improving. National Fertilizer Development Center, Islamabad, Pakistan, pp. 187–202.
- KIZIL, U., AKSU, S. and CAMOGLU G., 2018, Kontrollü ortamda bitkisel yetiştiricilik için arduino uyumlu bir toprak nemi izleme sistemi tasarımı, Comü Ziraat Fakültesi Dergisi, vol.6:131-139.
- LEVITT, J., 1980, Responses of plant to environmental stress: water, radiation, salt and other stresses, Academic Press, New York, 365.
- MAHMOUDA, E.S.A., HASSANIN, M.A., BORHAMB, T.I. and EMARAA E.I.R., 2018, Tolerance of some sugar beet varieties to water stress, Agricultural Water Management, 201, 144–151.
- MANSURI, M., BABAZADEH, H., EMDAD, M. R. and TALEGHANI, D., 2018, Effect of deficit irrigation management on qualitative and quantitative yield of sugar beet (*Beta Vulgaris* L.) in Karaj Iran, Applied ecology and environmental research, 16(1):455-466.
- MARSCHNER, H., 1995, Mineral nutrition of higher plants, 2nd Ed. Academic Press, San Diego, California, USA.
- MASRI, M.I., RAMADAN, B.S., EL-SHAFI, A.M. and EL-KADY, M.S., 2015, Effect of water stress and fertilization on yield and quality of sugar beet under drip and sprinkler irrigation systems in sandy soil, Int. J. Agric. Sci., 5 (3), 414–425.
- MCDONNELL, P.M., GALLAGHER, P.A., KEARNEY, P. and CARROLL, P., 1966, Fertilizer use and sugar beet quality in Ireland, International Potash Institute, Bern, pp. 107-126.
- MILFORD, G.F.J., ARMSTRONG, M.J., JARVIS, P.J., HOUGHTON, B.J., BELLETT-TRAVERS, D.M., JONES, J. and LEIGH, R.A., 2000, Effect of potassium fertilizer on the yield, quality and potassium offtake of sugar beet crops grown on soils of different potassium status, Journal of Agricultural Science, 135, 1-10.

- MONREAL, J.A., JIMENEZ, E.T., REMESAL, E., MORILLO-VELARDE, R., GARCIA-MAURINO, S. and ECHEVARRIA, C. 2007, Proline content of sugar beet storage roots: Response to water deficit and nitrogen fertilization at field conditions, *Environ. Exp. Bot.*, 60:267–267
- MOUSTAFA, S.N. and DARWISH, S.D., 2001, Biochemical studies on the efficiency use of some nitrogen fertilizers for sugar beet production, *J. Agric. Sci. Mansoura Univ.*, 26: 2421–2439.
- MUBARAK, M.U., ZAHIR, M., AHMAD, S. and WAKEEL, A., 2016, Sugar beet yield and industrial sugar contents improved by potassium fertilization under scarce and adequate moisture conditions, *Journal of Integrative Agriculture*, 15(11): 2620–2626.
- REINEFELD, E., EMMERICH, A., BAUMGARTEN, G., WINNER, C. and BEISS, U., 1974, Zur Voraussage des Melassezuckers aus Rübenanalysen, *Zucker* 27:2-15.
- RICHARDSON, A.D., AIKENS, M., BERLYN G.P. and MARSHALL. P., 2004. Drought stress and paper birch (*Betula papyrifera*) seedlings: effects of an organic biostimulant on plant health and stress tolerance, and detection of stress effects with instrument-based, noninvasive methods, *Journal of Arboriculture*, 30(1):52–61.
- SHALABY, M.T., DOMA, M.B., ABD-EL-LATIEF, F.A. and EL-SADIK, S.M., 2002, Agricultural, chemical and technological studies of potassium application on yield, chemical constituents and juice quality characteristics of sugar beet, *J. Agric. Sci., Mansoura Univ.*, 27: 7503–7512.
- SHEHATA, M.M., AZER, S.A. and MOSTAFA, S.N., 2000, The effect of soil moisture stress on some sugar beet varieties, *Egypt. J. Agric. Res.*, 78 (3), 1141–1160.
- TERZI, R. and KADIOGLU, A. 2006, Drought stress tolerance and the antioxidant enzyme system in ctenanthe setosa, *Acta Biologica Cracoviensia Series Botanica*, 48(2):89–96.
- TOPAK, R., SUHERI, S., and ACAR, B., 2011, Effect of different drip irrigation regimes on sugar beet (*Beta vulgaris* L.) yield, quality and water use efficiency in Middle Anatolian, Turkey, *Irrig Sci*, 29(1): 79-89.
- TURHAN, M. and PISKIN, A., 2005, Farklı dozlarda uygulanan potasyumun şeker pancarının verim ve kalitesine etkisi. Potassium and its importance in agriculture aymposium. Eskisehir. Turkey.
- UCAN, K., GENCOGLAN, C., 2004, The effect of water deficit on yield and yield components of sugar beet, *Turk J Agric For*, 28(3):163-172.
- WANG, X.G., ZHAO, H.Z.X, JIANG, J.C., LI, H.C., CONG, S., WU, D., CHEN, Y.Q., YU. H.Q. and WANG. C.Y., 2015, Effects of potassium deficiency on photosynthesis and photoprotection mechanisms in soybean (*Glycine max* L.), *Journal of Integrative Agriculture*, 14, 856–863.
- YONTS, C.D. 2011, Development of season long deficit irrigation strategies for sugar beet, *International Sugar Journal*, 113:728-731.
- YORDANOV, I., VELIKOVA, V. and TSONEV, T., 2003, Plant responses to drought and stress tolerance, *Bulg. J. Plant Physiol, Special Issue*:187–206.
- ZAHOOR, R., ZHAO, W., ABID, M., DONG, H. and ZHOU, Z., 2017, Title: Potassium application regulates nitrogen metabolism and osmotic adjustment in cotton (*Gossypium hirsutum* L.) functional leaf under drought stress, *Journal of Plant Physiology*, 215, 30–38.
- ZHANG, Z., WEIJING, Q and XIAOFANG L., 2009, Experimental guide of plant physiology, Beijing: Higher Education Press.

Journal of Scientific Perspectives

Volume 4, Issue 2, Year 2020, pp. 169-176

E - ISSN: 2587-3008

URL: <https://ratingacademy.com.tr/ojs/index.php/jsp>

DOI: <https://doi.org/10.26900/jsp.4.014>

Research Article

EFFECTS OF GINGER EXTRACTS ON TOTAL PROTEIN AMOUNT AND PEROXIDASE ACTIVITY IN SOLANUM LYCOPERSICUM L.

*Zeynep ÖZCEYLAN** & *Cüneyt AKI***

* MSc Student, Çanakkale Onsekiz Mart University, Graduate School of Natural and Applied Sciences, TURKEY, e-mail: zeynepozceylan@gmail.com
ORCID: <https://orcid.org/0000-0002-1184-1943>

** Prof. Dr., Çanakkale Onsekiz Mart University, Faculty of Science and Arts, Department of Biology, Subdivision of Molecular Biology, TURKEY, e-mail: cuneytaki@comu.edu.tr
ORCID: <https://orcid.org/0000-0002-7486-2282>

Received: 2 February 2020, Accepted: 14 April 2020

ABSTRACT

Zingiber officinale Roscoe, belonging to the Zingiberaceae family, is a medicinal plant that also spreads in our country. In this research, extracts of *Z. officinale* rhizomes were prepared with different solvents (ethanol, methanol, distilled water, DMSO). *Zingiber* rhizome extracts were sprayed on the leaves of rio grande and marmande varieties of 10-12 weeks old *Solanum lycopersicum* plantlets. Total protein amount and peroxidase activity were examined by spectrophotometrically 24 and 48 hours after the application. According to the results, it was determined that the maximum increase in the total protein amount compared with the control group was 31.31% and 25.53% in marmande and rio grande varieties in ginger rhizome extract prepared with methanol, respectively. The increase in peroxidase activity was determined as 144.14% and 124.85% in marmande and rio grande varieties in ginger rhizome extract prepared with ethanol, respectively. As a result of our research, it was determined that rhizome extracts of *Z. officinale* can be used as natural plant activator.

Key words: *Zingiber officinale*, *Solanum lycopersicum*, total protein, peroxidase

1. INTRODUCTION

Humans have used the protective and therapeutic properties of plants extensively for a long time (Dündar, 2001). After the 1900s, people discovered the side effects of synthetic drugs and the harm caused by synthetic substances in food and beverages to human health with the awareness, the demand for natural products has increased (Acibuca and Budak, 2018).

As in the whole world, the plants in the natural flora in our country are among the people for therapeutic purposes, food, tea, spice, dye, insecticide, treatment of animal diseases, resin, use of gum, volatile oils, long use in soft drinks and cosmetic industry has been a part of our traditional cultural wealth that has been going on for years (Faydaoğlu and Sürücüoğlu, 2011).

Ginger is a species belonging to the Zingiberaceae family. This family of up to 24 genera and around 300 species. The genus *Zingiber* has also about 20 species. Ginger plant perennial has tuber or rhizome roots. Plant up to 60-90 cm high, single with dark green leaves forms an annual stalk. There are two rows of 8-12 leaves on the stem. The leaves are long sheathed, alternate, lanceolate, strip-lanceolate, pointed, flat and stemless sheathed, 10-21 cm long, 2-2.5 cm wide. The flowers are small and pale yellow (Felter and Loyd, 2002).

The homeland of the tomato plant is Peru, one of the countries of South America. In the 19th century, tomato plant arrived to Turkey after via Syria. (Kaya et al., 2018). Tomatoes are a rich source of minerals, vitamins, organic acids, essential amino acids and nutrients (Kabelka et al., 2004). It is the richest and most important source of lycopene with antioxidant effect. Lycopene does not act as a vitamin, it is a precursor when taken into the body. However, its antioxidant property is very valuable. It has been scientifically recorded that high lycopene value in the blood prevents prostate cancer (Gann et al., 1999). As it can be consumed fresh in our country as in the whole world; It is also widely consumed as tomato paste, sauce and ketchup (Sönmez and Ellialtıoğlu, 2014).

Plants are exposed to negative effects of pathogenic organisms such as viruses, bacteria, protozoa, nematodes, fungi and various environmental conditions. They have developed many defense mechanisms to protect themselves from pathogen attacks. During this defense, while using chemical compounds such as pathogenic hydrolytic enzyme, toxin, plants have a large number of defense substances, including physical barriers, defense peptides, antioxidants, secondary metabolites and antimicrobial proteins. Antioxidants are involved in preventing cellular damage. Compounds in this defense minimize the damage caused by pathogens (Koç and Üstün, 2008).

Jana et al. (1999) observed that ginger had an anti-inflammatory effect compared to control as a result of their study with *Zingiber officinale*, *Vitex negundo* and *Tinospora cordifolia* to treat inflammation in the feet of albino rats.

Liu and colleagues, who developed new strategies to improve the response to chemotherapy in recurrent endometrial cancer, showed that terpenes found in ginger extract obtained by steam distillation have the potential to inhibit proliferation of endometrial cancer cells (Liu et al., 2012).

Raaof et al. (2013) evaluated the activity of the three plants (*Zingiber officinale*, *Thymus vulgaris* and *Acacia arabica*) as the coagulating agent using the removal of the crude alkaloids and three fragmented concentrations of each plant extract, and observed them in laboratory mice.

Türküsay and Tosun (2005) used copper hydroxide 361.1 g/L (champ formula) and hydrogen peroxide 580 g/L (HuwaSan TR50) against *Clavibacter michiganensis* as a plant activator. In their study with HuwaSan TR50+Champ Formula, they determined that the effect

obtained in co-administration was higher than the use of activator alone, and that the total protein and peroxidase enzyme activities were found at the highest level in the plants where this application was performed.

As a result of the literature review, there are no studies have been found on how the ginger rhizome extracts which we used in our research affected on the total protein amount and peroxidase activity on another plant. In our research, it has been demonstrated that the rhizome extracts of ginger obtained by using different solvents have different stimulating effects on the defense system in marmande and rio grande varieties of *S. lycopersicum*, depending on the variety, type of extract, exposure time. Effects of ginger rhizome extracts have been calculated by total protein amount and peroxidase activity changing.

2. MATERIAL AND METHODS

2.1. Plant Growth

Marmande and Rio Grande varieties of *S. lycopersicum* used in the research have been regularly watered with distilled water in pots with 1:3 perlite:soil at the temperature of $24\pm 2^{\circ}\text{C}$, 28.000 lux light, under the conditions of 16 hours light and 8 hours dark. Plantlets were grown in controlled plant chamber.

2.2. Preparing of Ginger Rhizome Extracts

Rhizomes of *Z. officinale*, originating in China, were obtained from a local market. After the rhizomes are dried in the shade at room temperature, they are powdered with the help of a warden blender. Powdered rhizome extracts were prepared with water, ethanol, methanol, and DMSO solvents. Extraction was done by taking the prepared solutions into the flasks and stirring at 110 rpm for 24 hours at 50°C in the shaker. The solvents were then kept in a water bath for 24 hours at 55°C for evaporation. The powder from the extracts removed from the water bath was weighed on a scale. Stock solution was prepared with 100 mL of DMSO by taking 10 g of the ginger rhizome powder. Two different concentrations were prepared by diluting with distilled water from the stock solution as 0.01 mg/mL and 0.02 mg/mL.

2.3. Application of Ginger Rhizome Extracts to The Plantlets

The prepared ginger rhizome extracts were applied to the leaves of 12 weeks old *S. lycopersicum* seedlings (Marmande and Rio Grande varieties) in equal amounts with the help of a pulverizator. Healthy and young leaves of the seedlings were harvested 24 and 48 hours after application. From each application groups 0.5 g of the fresh leaf have been weighted.

2.4. Leaf Homogenization

These leaves were crushed together with 5mL cold 0.05M sodium acetate buffer (pH 6.5) in cooled porcelain mortar for one minute. The homogenates were transferred to the 3 eppendorfs after being filtered from the filter paper. Then these homogenants were centrifuged 13000 rpm at $+4^{\circ}\text{C}$ for 15 minutes. After the centrifugation, the supernatant were used for determination of total protein amount and peroxidase (POX) activity spectrophotometric analysis. All trials were carried out in triplicate.

2.5. Determination of Total Protein Amount

For the protein amount measuring, homogenates were transferred to the glass test tubes as 100 μL from the eppendorfs and 5 mL of Protein Reagent Blue G-250 was added to each test tube. The total protein amount in the homogenates was determined by according to Bradford (1976)'s method using bovine serum albumin (BSA) as a standard. All trials were carried out in triplicate.

2.6. Determination of Peroxidase (POX) Activity

POX activity changes were performed by spectrophotometric analysis according to Kanner and Kinsella (1983). During the determination of the POX kinetic reaction, the spectrophotometer measured at 300nm for 2 minutes. The biggest differences between the absorbance values taken in every 10 seconds for 2 minutes periods are determined for each group. These determined differences have been converted to mg protein level and given as mg/ml/min POX enzyme activity. All POX activity measurements were performed in three replicates.

3. RESULTS AND DISCUSSION

3.1. Total Protein Results

The effects of *Z. officinale* rhizome extracts on the total protein amounts in marmande and rio grande varieties were given in Figure 1 and Figure 2.

Fig 1. Effects of *Z. officinale* extracts on Total Protein Amount in *S. lycopersicum* var. Marmande *Blue: 24 hours, *Red: 48 hours

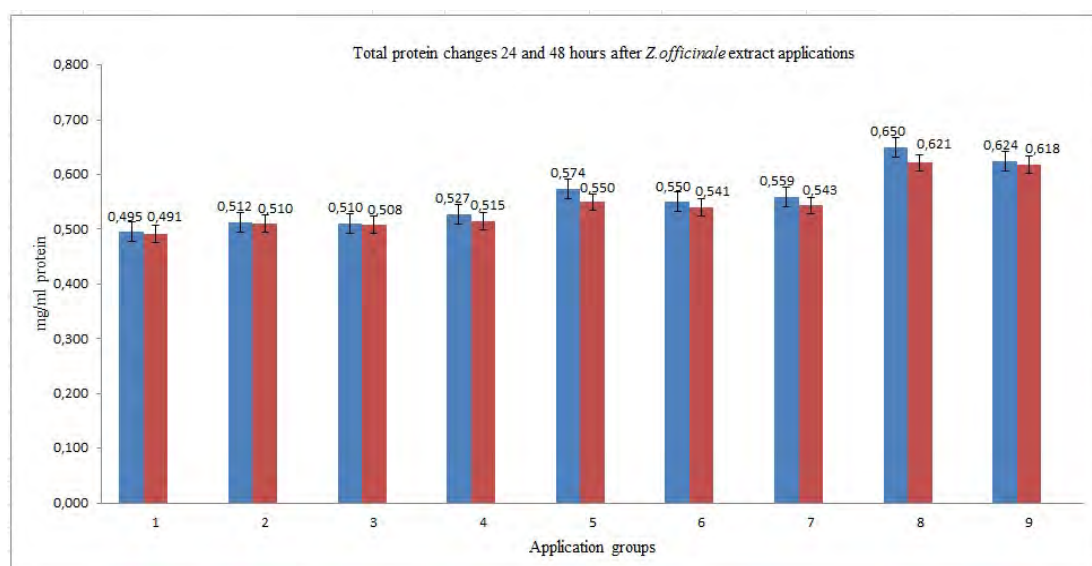
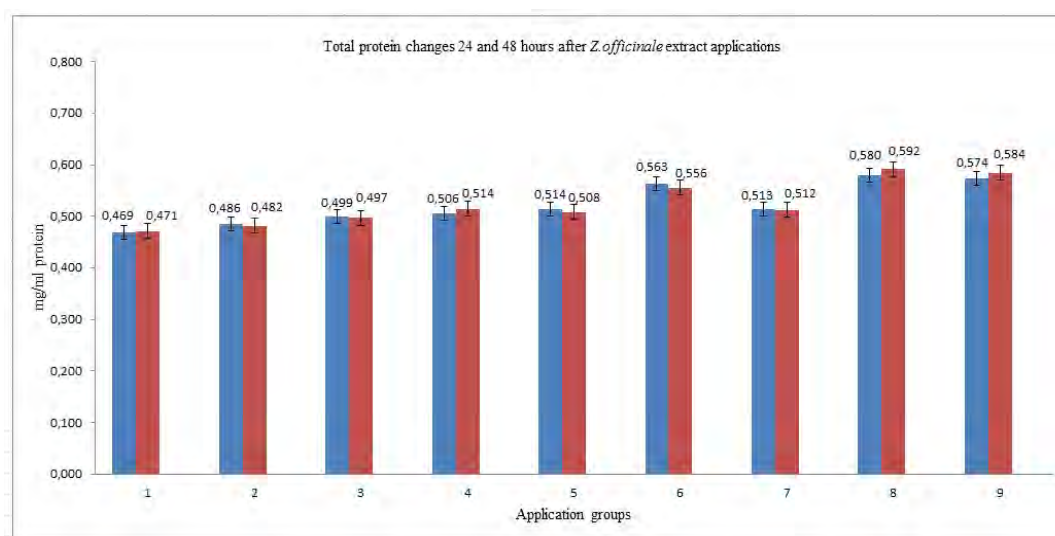


Fig 2. Effects of *Z. officinale* extracts on Total Protein Amount in *S. lycopersicum* var. Rio Grande *Blue: 24 hours, *Red: 48 hours



When compared with the control group, the highest increase in the amount of protein 24 and 48 hours after application have been measured as 31.31% and 25.53% respectively in the 8th group (methanol extracts of rhizome) in the marmande and rio grande varieties of *S. lycopersicum*.

When compared with the control group, it was determined that all ginger extracts which prepared with different solvents such as distilled water, DMSO, ethanol, methanol caused an increasing in the total protein amounts.

3.2. Peroxidase Results

The effects of *Z. officinale* rhizome extracts on the peroxidase activity in marmande and rio grande varieties were given in Figure 3 and Figure 4.

Fig 3. Effects of *Z. officinale* extracts on POX activities in *S. lycopersicum* var. Marmande
*Red: 24 hours, Green: 48 hours

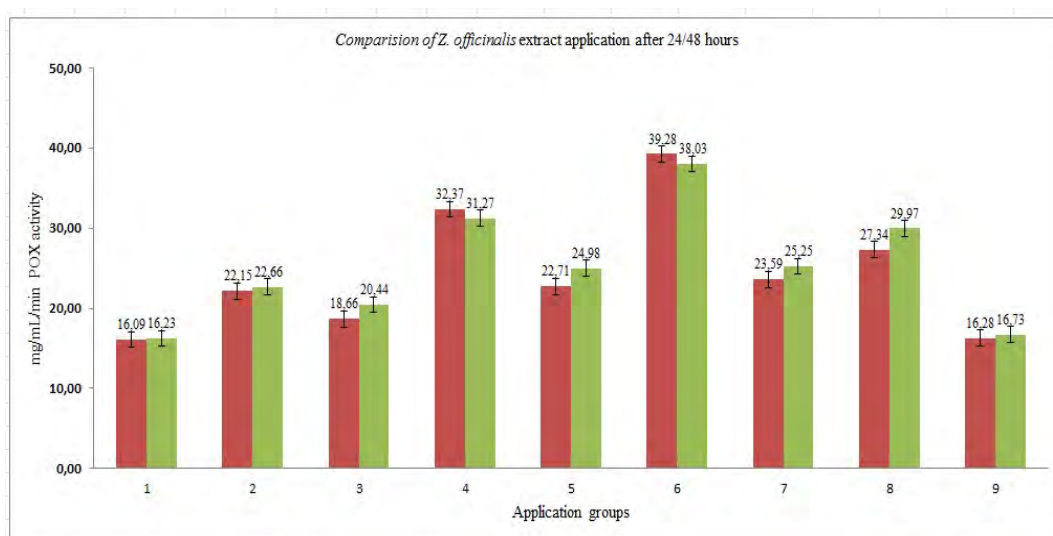
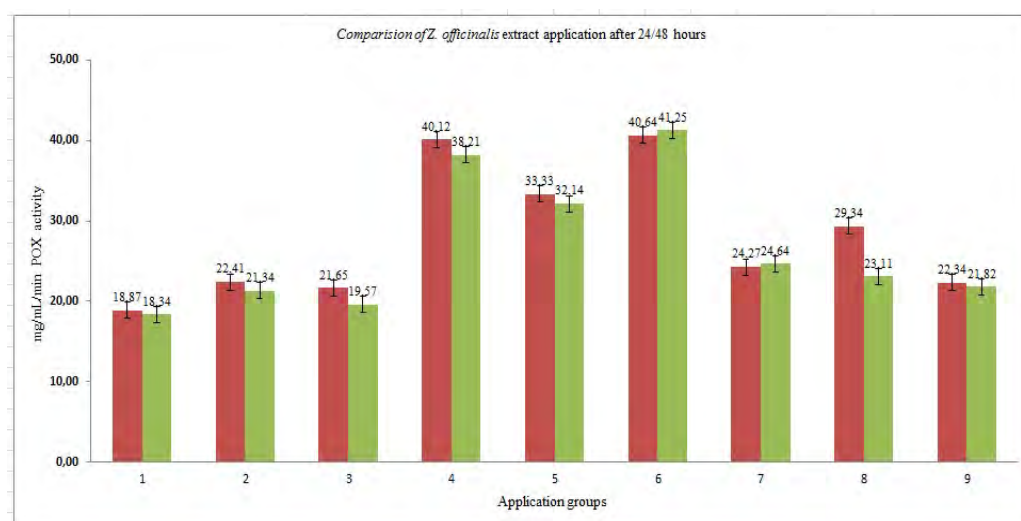


Fig 4. Effects of *Z. officinale* extracts on POX activities in *S. lycopersicum* var. Rio Grande
*Red: 24 hours, Green: 48 hours



After the application of *Z. officinale* rhizome extracts, peroxidase activity increased in all application groups of marmande and rio grande varieties when compared with control group. The highest increase in the peroxidase activity 24 and 48 hours after application have been measured as 144,14% and 124,85% respectively in the 6th group (ethanol extract) of marmande and rio grande varieties of *S. lycopersicum*.

3.3. Discussion

As a result of our research, it was observed that ginger rhizome extracts which prepared using different solvents, affected plant defense system in different degrees both tomato varieties.

In the research of Yıldız and Akı (2019), it was shown that *Prunus spinosa* and *Rubus sanctus* fruit extracts have been stimulated the plant defense system in grossum and conoides varieties of pepper at different levels within the scope of total protein amount and peroxidase activity according to the control group.

There are another research that was determined the effect of *P. spinosa* and *R. sanctus* leaf extracts on the total protein amount and POX activity in pepper varieties (Yıldız and Akı, 2018).

In another research on *S. lycopersicum*, changing in both protein and peroxidase levels were occurred after *Echinacea angustifolia* extract applications according to concentrations and exposure time. Amount of total protein changing after Echinacea application in total protein levels were decreased 48 hours after 0.03g/mL Echinacea extract applications in DMSO, DMSO+methanol, DMSO+ethanol groups respectively as 43.16%, 29.32% and 27.26%. Peroxidase activity were increased 48 hours after 0.03g/mL Echinacea applications in DMSO, DMSO+methanol, DMSO+ethanol groups respectively as 43.16%, 62.60%, 38.20%, 38.95%.

As a result of this research, echinacea extracts which is prepared with two different concentrations and exposure times were stimulate the plant defense system as a plant activator as well (Dinç and Akı, 2015).

All of this researches are showing that some other researchers are trying to find natural plant activators. Our research results also parallel with other research results.

In our research, it has been demonstrated that extracts prepared from the rhizomes of *Z. officinale* plant using distilled water, DMSO, ethanol and methanol solvents can be used as a natural plant activator in certain proportions.

4. CONCLUSION

In conclusion, the application of ethanolic and methanolic extract of ginger rhizome in different concentrations and exposure times to the *S. lycopersicum* plantlets have been stimulated the tomato defence system. Our research results are showing that appropriate concentrations of ginger rhizome extracts can be use as a natural plant activator for stimulate the plant defense system. Instead of synthetically prepared or microbial originated plant activators/biostimulators, this kind of natural extracts can be use for growth healthy seedlings.

NOTES

The codes of the application groups prepared from the 100 mg/mL stock solution of ginger rhizomes used in the research are as follows;

- (1) Control Only distilled water application
- (2) 0.01 mg/mL Only DMSO application
- (3) 0.02 mg/mL Only DMSO application
- (4) 0.01 mg/mL Ginger rhizome prepared with distilled water
- (5) 0.02 mg/mL Ginger rhizome prepared with distilled water
- (6) 0.01 mg/mL Ginger rhizome prepared with ethanol
- (7) 0.02 mg/mL Ginger rhizome prepared with ethanol
- (8) 0.01 mg/mL Ginger rhizome prepared with methanol
- (9) 0.02 mg/mL Ginger rhizome prepared with methanol

REFERENCES

- ACIBUCA, V., BUDAK, D. B., 2018. Dünya’da ve Türkiye’de Tıbbi ve Aromatik Bitkilerin Yeri ve Önemi. *Çukurova Tarım ve Gıda Bilimleri Dergisi*, 33(1), 37-44.
- BRADFORD, M. M., 1976. A Rapid and Sensitive Method for the Quantitation of Microgram Quantities of Protein Utilizing The Principle of Protein Dye Binding. *Analytical Biochemistry*, 72: 248-254.
- DİNÇ, A.G., and AKI, C., 2015. Effects of *Echinacea angustifolia* Hell. extracts on total protein and peroxidase changing in *Solanum lycopersicum L.*, *Annals of Biological Research*, 6 (12), 25-29.
- DÜNDAR, Y., 2001. Fitokimyasallar ve Sağlıklı Yaşam, Afyon Kocatepe Üniversitesi, *Kocatepe Tıp Dergisi*, 2,131-138
- FAYDALIOĞLU, E., SÜRÜCÜOĞLU, M. S., 2011. Geçmişten Günümüze Tıbbi ve Aromatik Bitkilerin Kullanılması ve Ekonomik Önemi. Kastamonu Üniversitesi, *Orman Fakültesi Dergisi* 11 (1):52-67.
- FELTER, H.W., LOYD, J.U., 2002. Zingiber (U.S.P.) Ginger. King's American Dispensatory. www.ibiblio.org/hermed/eclectic/kinga/zingiber.
- GANN, P.H., MA, J., CIOVANNUCCI, E., WILLET, W., SACKS, F.M., HENNEKENS, C.H., STAMPFER, M.J., 1999. Lower prostate cancer risk in man with elevated plasma lycopene levels: results of a prospective analysis. *Cancer Research*, 59:(6), 1225-1230.

- JANA, U., CHATTOPADHYAY, N.R., SHAW, B., 1999. Preliminary Studies On Anti-Inflammatory Activity of *Zingiber officinale* Rosc., *Vitex negundo* Linn. and *Tinospora cordifolia* (willid) miers in Albino Rats., *Indian Journal of Pharmacology* 31, 232-233.
- KABELKA, E., YANG, W., FRANCIS, D.M., 2004. Improved tomato fruit color within an inbred backcross line derived from *Lycopersicon esculentum* and *L. hirsutum* involves the interaction of loci. *Journal of the American Society for Horticultural Science*, 129 (2):250-257.
- KANNER, J., KINSELLA, J.E., 1983. Lipid Deterioration Initiated by Phagocytic Cells in Muscle Foods: β -Carotene Destruction by a Myeloperoxidase-Hydrogen Peroxide-Halide System. *Journal of Agricultural and Food Chemistry*, 31: 370-376.
- KAYA, Y., AL-REMİ, F., ARVAS, Y.E., DURMUŞ, M., 2018. Domates Bitkisi Ve in Vitro Mikro Çoğaltımı (Tomato Plant and Its In Vitro Micropropagation). *Journal of Engineering Technology and Applied Sciences*, 3(1), 57-73.
- KOÇ, E., ÜSTÜN, A.S., 2008. Patojenlere karşı bitkilerde savunma ve antioksidanlar. *Erciyes Üniversitesi Fen Bilimleri Enstitüsü Dergisi* 24 (1), 82-100.
- LIU, Y, WHELAN, RJ, PATTNAIK, BR, LUDWIG, K, SUBUDHI, E, ROWLAND, H, CLAUSSEN, N, ZUCKER, N, UPPAL, S, KUSHNER, DM, FELDER, M, PATANKAR MS, KAPUR A., 2012. Terpenoids from *Zingiber officinale* (Ginger) induce apoptosis in endometrial cancer cells through the activation of p53. *PLoS ONE*, 7, (12).
- RAAOF, A., AL-NAQQASH, Z.A., JAWAD, A.M, MUHSAN, S.M., 2013. Evaluation of the Activity of Crude Alkaloids Extracts of *Zingiber officinale* Roscoe., *Thymus vulgaris* L. and *Acacia arabica* L. as Coagulant Agent in Lab Mice, *Biomedicine and Biotechnology*, 1 (2), 11-16.
- SÖNMEZ, K., ELLİALTIOĞLU, Ş., 2014. Domates, karotenoidler ve bunları etkileyen faktörler üzerine bir inceleme, *Derim*, 31 (2): 107-130.
- TÜRKÜSAY, H., TOSUN, N., 2005. Hidrojen Peroksit Uygulamalarının Domates Bakteriyel Solgunluk ve Kanser Hastalığı (*Clavibacter michiganensis* spp. *michiganensis* (Smith) Davis et al)'na Etkileri. *Ege Üniversitesi Ziraat Fakültesi Dergisi*, 42(2), 45-56.
- YILDIZ, C., AKI, C., 2018. *Prunus spinosa* L. ve *Rubus sanctus* Schreb. Yaprak Ekstraktlarının *Capsicum annuum* L. Çeşitlerinde Toplam Protein Miktarı ve Peroksidaz Aktivitesi Üzerine Etkilerinin Belirlenmesi, *Journal of Awareness*, 3(5), 609-616.
- YILDIZ, C., AKI, C., 2019. Effects of Blackberry and Blackthorn Fruit Extracts on Protein and Peroxidase Activity In Pepper. *Journal of Scientific Perspectives*, 3(3), 237-244.